

May - June 2016

THE LEADING FLORICULTURAL JOURNAL IN THE REGION

FLORICULTURE

Kshs. 350

Tshs. 3,500

S.A. Rands 35

USD 6



Mr. Dick Van Raamsdonk

Being there is the Name of the Game



ELGON KENYA LIMITED



Flower Sleeves

ROTO GRAVURE PRINTING MACHINE



Printed Flower Sleeves

- . 10 Colour gravure printing machine.**
- . Latest computerized technology.**
- . Very precise graphics printing.**
- . Very quick delivery times.**

East Gate Road, Off Mombasa Road, P.O. Box 46826-00100, Nairobi, Kenya

Contact: Yogi Yagnik Cell: 0733-986219.

Wireless: (020) 2399981/3/98 Mobile: 0733-699992, 0722-203089

E-mail: info@elgonkenya.com Website: www.elgonkenya.com



If you love life you will love Luna



Bayer CropScience is proud to present you with an outstanding new fungicide whose unparalleled efficacy on powdery mildew and botrytis leads to:

- Improved produce quality
- Longer vase-life
- Outstanding disease control
- Increased marketability



Bayer CropScience



Inside

- 6. Six Key Benefits of IFTEX
- 13. Testing Water and Fertilizer Solution
- 16. Hydroponics - The Farming Of The Future?
- 22. Tradecorp Discusses Crop Nutrition
- 26. Kenya Flower Council at Twenty
- 30. Making Progress, Driving Change
- 36. Matt Fryer at the Helm of Arysta LifeScience
- 48. Be wary of downy mildew
- 52. Briefs
- 56. East African Packaging Ltd

The Leading Floriculture Magazine

Contributions to **Floriculture** are welcome. Although every effort will be made to return manuscripts and photographs, these are submitted at owners' risk. Opinion expressed by contributors are not necessarily the views of **Floriculture**. All rights reserved. Reproduction in whole or in part without written permission of the publishers is strictly prohibited. **Floriculture** is published six times a year and circulated to personnel in the Horticulture Industry, foreign missions and Kenyan Embassies abroad, Flower Growers, Exporters and Consumers, extension officers in the Ministry of Agriculture, research offices and suppliers of agricultural inputs in Kenya.

FUNGICIDE

Fungaflo[®] 100 EC

100 g/L Imazalil

A systemic fungicide with curative and protectant properties



- ◆ Primary activity against botrytis and powdery mildew
- ◆ Secondary activity on alternaria, downey mildew and rust
- ◆ Fully systemic: active ingredient will target all plants parts when sprayed
- ◆ No side effects on beneficial insects and bees
- ◆ One day pre-harvest interval

Distributed by:



Arysta LifeScience (K) Ltd.
Tulip House, 5th Floor, Mombasa Road
P.O. Box 30335-00100 GPO, Nairobi, KENYA

Tel: +254 717 432 174
Email: arysta.kenya@arysta.com

Keep Going

Lately, I've had to deal with a lot of changes happening in floriculture industry. At first, describing them to my friends, I kept calling them endings, but afterwards I began to feel as if it was a process of renewal. There is a Chinese saying that goes. 'if the old doesn't go, the new cannot come'. Keeping that in mind, I've begun to view these difficult events as a shedding of things for me to grow forward, and so I've come to call them 'changes' instead of 'endings'. The Flower industry has faced a lot of challenges for the last few years and it needs a motivational speaker to cheer these up. Although I'm never one but allow me to share wisdom from the Ninja village.

As I grew up, I was a great fan of the popular Ninja Films. This led me to be a student of the Bujinkan. The word Bujinkan means the Training Hall of the Warrior Spirit, and was a Japanese martial arts organization composed of 9 schools of traditional Japanese martial arts, 3 of which were ninjutsu schools.

A powerful lesson that stuck in my head through the years was something I first read from The Grandmaster's Book of Ninja Training by our grandmaster, sōke Masaaki Hatsumi, and I quote: People create all their barriers for themselves. It's really such a foolish thing to do. We create our own obstacles and lose our own way in the search for truth. All that it's necessary to do when one faces a barrier is just keep walking, paying no attention. Just keep going, keep walking, and the obstacles disappear! In my case, when I appear to be in trouble and I think I won't make it, I just keep walking. And so it continues, even today.

The character for the word nin in ninja means 'to endure' or 'to persevere'. It combines the character for knife on top of the character for heart; it means to go on despite having your heart under the knife! Thus, a ninja is somebody who perseveres with his heart's intentions even under threat or pressure. This ninja philosophy is really simple to remember, and is summed up in 2 words: keep going.

Which sounds surprisingly like what another



master martial artist, Bruce Lee, said (from the book The Warrior Within: The Philosophies of Bruce Lee): It's just a case of learning to look at hardship as if today the rain is coming on strong, but tomorrow, the sun is going to come out again. And in a letter Bruce sent to one of his closest friends while the latter was going through a profound hardship: Life is an ever-flowing process and somewhere on the path some unpleasant things will pop up - it might leave a scar - but then life is flowing on, and like running water, when it stops, it grows stale. Go bravely on, my friend, because each experience teaches us a lesson.

And this is my message to all growers 'if the old doesn't go, the new cannot come'.

Keep going...



Publishers of Floriculture Magazine

P.O.BOX 79396 - 00200 Nairobi.
Tel: 020-2440909 • Cell 0732-558172,
Fax: 020-2244892
Email: info@florinews.com
Website: www.florinews.com

Floriculture Team

Editor

Masila Kanyingi

Editorial Assistant

Cornelius Mueke

Contributors

Ruth Anita Vaughan
Nelson Maina
Joseph Maina
Flowerweb
Agrichem Africa Ltd
Kenya Flower Council
Matt Fryer
Angus Ker
James Cocker
Lance Lawson

Photographers

Jairus Ndani

Graphic Designer

Evelyne Ndiema

Marketing

Beatrice Kariuki
Benard Muendo
Wilbur Njemah

Editorial Consultants

Tom Ochieng - Penta Flowers
Victor Juma - Syngenta EA Ltd
Oscar Shilliebo - Dow Agrosience
Charles Njuki - Flamingo Holdings
Patrick Ngugi - BASF
Daniel Kisongwo - Consultant
Innocent Anunda - Arysta LifeScience
Maurice Koome - Bayer Cropscience
Anthony Songoro - Bayer Cropscience

IRON EARTH

FE 6% WSP + 40% HUMIC ACIDS

100% Water Soluble Iron Humate for soil & foliar application

- **Environment friendly** source of iron versus traditional chelated sources
- **Increases** iron and nutrient uptake through the roots
- **Immediate** availability of iron
- **Contains** humic and fulvic acids, which **prevents oxidation** of iron and other existing micronutrients
- **Improves** water holding capacity of soils over time
- **Reduces** leaching
- **Natural** chelating agent for microelements in alkaline & calcareous soils
- Acts as an **anti-stress agent**
- EDDHA chelates contain sodium unlike ironearth



Ironearth is a 100% water soluble iron humate in powder form containing 6% iron in chelated form plus humic acids in a readily available form for plants. It is made through extraction of leonardite and addition of mineral iron salts.

Iron in plants is associated with the formation of chlorophyll, an essential element to ensure plant health. Deficiency of Iron can be seen on the leaves where the leaves have interveinal chlorosis and appear light green to yellow in colour.

Ironearth provides iron in an easily absorbed form through foliage when sprayed on the leaves or through the roots when used through irrigation systems. It can be used for all horticultural and floricultural crops for correction of iron deficiency. In addition to iron, the presence of humic acids in Ironearth assists in improving the overall health of plants and resistance against stress. Applied to soils, it can improve the performance of regular fertilisers.

COMPOSITION OF IRONEARTH:

- Humic Acids 40%
- Chelated/complexed Iron 6%
- Solubility in water 100%
- Saturated solution ~100 g/L
- Stability pH range 6-11
- pH-value (in 20% solution) 8-9

DIRECTION FOR USE: PLEASE READ THE LABEL CAREFULLY

- Ironearth should be used for correction of iron deficiency, soil conditioning and increase of soil fertility.
- Mix the recommended amount into water (the chart below is a guideline) in a spray / mixing tank and apply as a foliar, drench or soil application through sprinkler, drip or surface irrigation systems.
- Ironearth can be used on its own or mixed with soluble fertiliser formulations (soluble NPK, MAP, DAP or urea) and herbicides. However always carry out a miscibility test before first application of a mixture.
- Always carry out a phytotoxicity test on a small area before large scale application.

CROP	RECOMMENDED FOLIAR APPLICATION	RECOMMENDED SOIL APPLICATION
Roses	0.5g/L week	40-50g / 100m ²
Green House Vegetables (tomatoes, peppers, eggplant, cucumbers, zucchini)	0.5-1g/L	6-8 Kg/Ha divided into several doses (1Kg/Ha)
Fruit Trees (citrus, banana)	5-10g/10L per tree	6-8 Kg/ (1Kg/Ha) or 100-150 g /tree
Field Vegetables (potatoes, beans, onions, tomatoes etc.)	1-1.5 Kg/1000L per Ha	4-6 Kg/Ha divided into several doses (1Kg/Ha)
Cereals (wheat, barley maize & other grains)	200g/L	4-6 Kg/Ha divided into several doses (1Kg/Ha)
Ornamental Plants, Trees & Shrubs, Grass	250g/L	6-8 Kg/Ha divided into several doses (1Kg/Ha)
All crops in general	300g/1000L water every 2-3 weeks	4-6 Kg/Ha divided into several doses (1Kg/Ha)

For Agriculture Use Only

Recycle Paper

Organix Limited
The Farmer's Environmental Friend

P.O.Box 14494
Nairobi 00800 Kenya

Tel: +254 20 3566241/2 / 3741482

Cell: +254 735 712090 / 720 937535

eco@organix-agro.com www.organix-agro.com

A Product of the E.U. • Available in 10 Kilo

Six Key Benefits IFTEX Show Has to Market Your Business

IFTEX has traditionally been a very popular exhibition to market your products, services and business. With advances in social media marketing and Internet technology, like webinars, Google hangouts and video conferencing, the value and benefits of marketing via trade fair comes up. Though technology is changing marketing at a rapid pace, there are several benefits from having exhibit presence at a trade show.

These six key benefits are why your business must have IFTEX Exhibition marketing presence:

1. IFTEX Creates Lasting Impressions If Done Right

The main purpose of IFTEX is to showcase a wide variety of options for attendees and business to engage and interact with each other. With a well-designed trade show booth that draws attendees' attention, a few promotional items, a contest opportunity with giveaways and sales collateral, you will have a well-rounded booth experience that leaves an impression with a prospective customer for months. Consider having attendees enter a drawing by submitting a business card or completing an action on social media. These types of promotions serve dual purposes: increasing engagement and capturing potential contact information as well.

2. IFTEX is Incredible Face-To-Face Marketing Event

When it comes to influencing a decision, nothing can compete with face-to-face interaction. IFTEX provides opportunities to engage with current buyers and prospective. It doesn't matter whether you're marketing a product or selling your new variety, an in-person presentation and short question based conversation

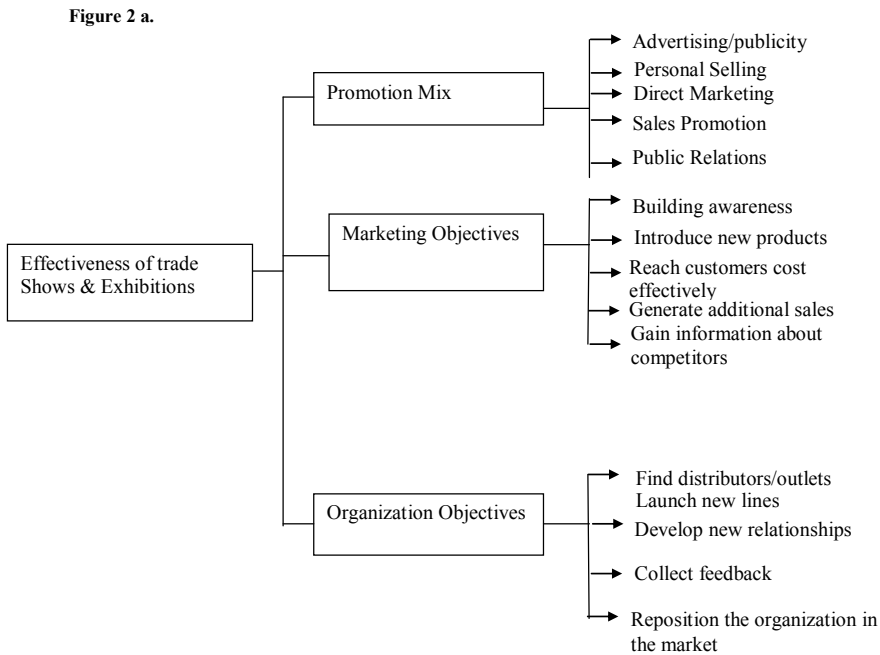

afterwards can help you to close the deal quickly versus an email sharing the latest sales promo. This makes pre-IFTEX planning key to your success. If you've got an employee who is a natural at "turning on the charm" or one who is great at relationship selling, should be a no brainer on them being a part of the sales team. The cost to bringing them to IFTEX show event could pay for itself within hours of the show starting.

3. IFTEX Lead Generation Potential

When it comes to benefits, this is one of the biggest. IFTEX has massive followings and attendance. Each attendee of IFTEX is a potential lead waiting to be captured. Having QR codes linked to social media accounts or lead generation pages, asking for contact information during a presentation and getting their business cards are all great ways to get fresh leads in your sales pipeline. Make it clear to them that you'll be contacting them after

the show. Make sure to follow up with the candidates most likely to buy while the event is still fresh in their mind.

4. IFTEX Target Audiences Result In Direct Sales Opportunities

IFTEX has a specific market or niche it focuses on. By exhibiting at IFTEX, the odds are very high that you'll have exposure to an audience that is likely to have an interest in your product or services and are ready to buy. ALWAYS have something to showcase at IFTEX. It doesn't matter if you only bring your old varieties or the newest, the opportunity to generate sales shouldn't be lost because you didn't have something. Don't miss out on that sale!

5. IFTEX is Cost-Effective Networking and Advertising

Designing the trade show booth, renting space on the trade show floor, traveling to the show and from the show, paying for lodging and meals can seem like a steep

CITY GENERAL STORES LIMITED

DEALERS IN : HARDWARE ,BUILDING MATERIAL,INDUSTRIAL SUPPLIES, AGRICULTURAL SUPPLIES
PROTECTIVE GEAR AND EQUIPMENTS, IRRIGATION AND DRIP IRRIGATION SYSTEMS.ETC
P.O. Box 190, Thika – Kenya, Tel: +254 67 22500, 22337, Fax: 067 30857, Mobile: +254 (0) 727 900 555, 733 817 540 , 704 622000
Email: sales@citygeneral.co.ke, citygeneral@africaonline.co.ke.



Leading Suppliers of:

Personal Protective Gear

Irrigation Pipes and Fittings

3M Protective Products

Hardware and Building Materials

Oils and Lubricants

Paints and Painting Materials

Stationery and Packaging, Adhesives

Power Tools and Hand Tools

Mul-T-Locks, Union, Viro Locking systems

Uniforms and Shoes

Timber and Wooden Poles

Water Tanks and Underground Tanks

Steam Pipes and Fittings

Electrical Lights and Switches

Cleansing Materials

Iron Strapping & Stitching Machines

Portable Bag closing Machines

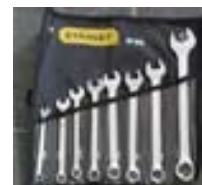
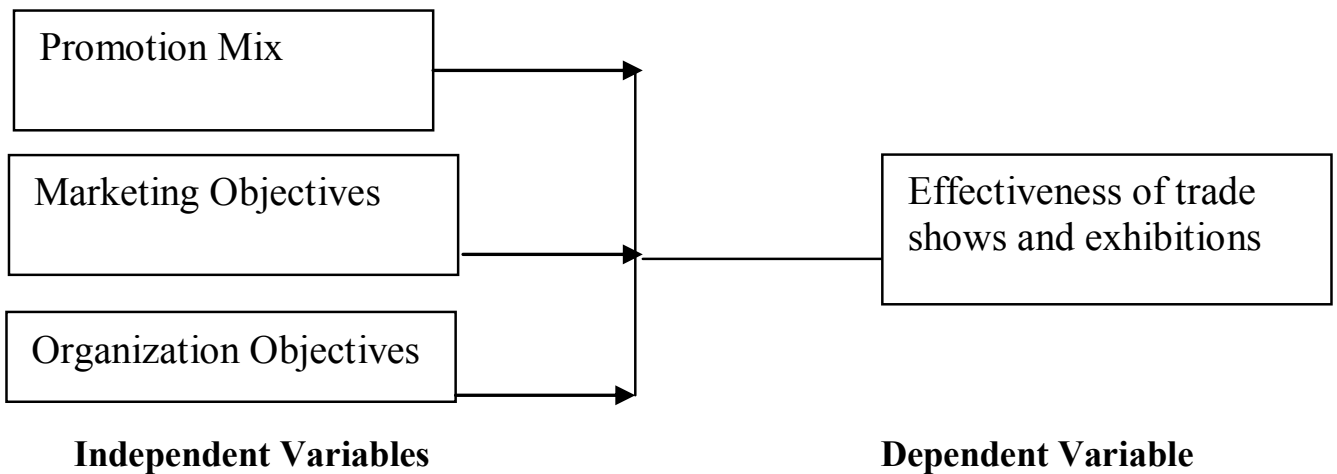

Figure 2 b.



price tag for a single marketing event. If you've done the pre-show marketing work leading up to the show, the potential that IFTEX offers your business can far exceed the investment.

Though you might have a larger initial investment to showcase your business at IFTEX than other advertising or networking methods, the cost to convert a prospect into a sale is often much lower than other alternatives. With proper research and planning, IFTEX is one of the most cost-effective sources of leads and sales possible.

6. IFTEX Level The Marketing Field

One of my favorite benefits to IFTEX is the low cost barrier to get involved. From locally owned small scale growers to multinational growers, everyone has access to the same attendees at IFTEX. It's almost as simple as paying for your exhibit location space, designing your trade show display booth, promoting your business leading up to IFTEX and interacting with the audience during the show. Even a relatively unknown grower can generate large numbers of sales and leads through IFTEX. Certainly this is possible via other marketing channels, but few are as easy to execute as IFTEX can be.

IFTEX offers big benefits to businesses of any size. By combining exposure to a large number of potential leads with the ability to interact personally, IFTEX offers an experience that other forms of marketing cannot.

3M Personal Safety Division



3M Has Your Health and Safety Needs Covered

When you have a job to do, the least of your worries should be your personal safety. Put your mind at ease when you protect yourself with 3M safety products. Not only will you find a vast range of effective occupational safety products from 3M, you'll also find comfort, style and value. 3M offers personal health and safety products for eye protection, hearing protection, active communication, respiratory protection and welding protection to provide the utmost in quality that meets and exceeds the most stringent safety requirements. 3M backs all product lines with qualified and knowledgeable local experts from the field. No matter the application, you'll find what you need because 3M is Health & Safety.



3M Kenya
 3M Kenya, Victoria Towers, Upper Hill, Nairobi
 Office: +254 202730626/7/8
 Fax: +254 20 2730629
 Internet: jmutuku@mmm.com | www.3M.com
 mnucheke@mmm.com



Being There is the Name of the Game

The 1979 film 'Being There', is the only screen performance for which actor Peter Sellers won an Oscar. Seller portrays a simple minded gardener turned from a sheltered existence into the harsh realities of life. Through a series of mishaps and misunderstandings, the gardener became a highly respected policy adviser to the president of United States.

The thinking on which the character builds his reputation and gains recognition as an authority is the simple philosophy that politics and business are very much like a garden-find or make the right sort of soil, plant it well, nurture it, feed it, and it will reward you well by providing for you year upon year.

And even in the world of commerce there is a reasonable analogy to be made.

As to how the film came by, its title you probably cannot do better than hazard guess that it was a reference to its main character 'Being There' in the right place in the right time.

And there can't be many who would disagree with that theory. Not in the Flower business at any rate, where 'Being There', in the right place at the right time can

be condensed into one word-'Marketing'.

'Being There' became very much the catchphrase when talking to Mr. Dick Van Raamsdonk, the President of HPP Exhibitions Holland. June is the month flower buyers should be packing their suitcases and Travelling to IFTEX, an international Floriculture Trade Fair. The fair to be held from 8th-10th June is organized by HPP Exhibitions and will bring together all growers of cut flowers and their buyers under one roof.



DAS HERZ DER FRISCHE

WHY IS
GREEN SO COOL?

CHILLVENTA
October 11-13, 2016
Hall 7, Booth 330

Because GREEN is BITZER! Your innovative partner for high efficiency and intelligent cooling solutions. We are at your side, all over the world, always. You can count on us and our products! Visit us at CHILLVENTA and learn more about BITZER at www.bitzer.de

During the interview, Mr. Dick Van Raamsdonk said unashamedly that he believed 'Being There' was the main commercial advantage to every Kenyan grower. Adding, "Buyers love Kenya Flowers and Kenya is currently the most exciting supplier to the buyers. To Europe, Kenya is what Ecuador and Colombia is for USA". He said Being There was the best way of meeting and networking with the right buyers.

Speaking exclusively to **Floriculture Magazine**, Mr. Dick Van Raamsdonk said Kenya has the right quality and price for buyers. He said the market is big enough and this is the right time Kenyan growers can make themselves the global flower suppliers. "Kenya has a business duty to present themselves in a big way in this year's IFTEX. This will give them an opportunity to meet not only the buyers but also the consumers and get to understand what they need, he added.

"Do Kenyan growers want to market themselves?" he asked. Then 'Being There' will be the best decision one can make. Mr. Dick Van Raamsdonk said that he had teamed up with the government institutions, flower organisations and growers to make the show very successful. Likening Kenya to a sleeping flower giant, Mr. Dick Van Raamsdonk said It was only in Kenya where you can get all flower sizes, most promising production and the right quality from one country all year round. "This is a golden chance to market these products to the most promising flower market currently", he said.

By no means the least of the reasons given and yet surprising not the first thought on every growers mind, this is an excellent way of meeting buyers. Kenyan growers will not only meet the right buyers but also keep their position as a leader in flower exports. It is a near suicidal for any grower who ignores his market. "It is my dream to bring the most promising flower producer (Kenya) and the most promising flower market together", he concluded.

Quality standards are always a top priority. And so everyone would like to share with the original breeder, grower, buyer and consumer. Those who will miss IFTEX will spend the next one year with the old technology, old contacts, old friends and business plus more aging mindset on how the market is evolving. Well the chance of 'Being There' is open you do not have to say when it's too late. "BUT NO BODY TOLD ME"

Why Exhibit

Trade fairs, conferences, business events, economic forums and exhibitions can be defined in a unified manner as sophisticated platform for conducting business on a national and international scale. It is more than just a marketing tool as the entire marketplace is at your fingertips. As a source of market information they fulfill your needs in a centralized way. Said Mr. Dick Van Raamsdonk.

IFTEX provide growers an excellent opportunity to assess opinions from buyers and determine market potential, conduct research and evaluate competition, develop commercial structures by identifying new agents and distributors, and initiating joint ventures and project partnerships. "IFTEX provides a unique networking platform to both local and foreign participants. It helps in promotion, marketing and publicity efforts of participating companies. It lead to joint ventures, tie-ups and also help bring in investment in the Country", says Mr. Dick Van Raamsdonk.

As a reliable media for exchange of information, IFTEX is being globally recognized as the apt medium for doing flower business today. In the words of Dick Van Raamsdonk, "The current economic slowdown is the ideal time for the industry to showcase its presence on exhibition floor as the industry is very much in a position to reinforce its tenacity, strength and collaborative nature".

In fact, in tough market conditions, it becomes all the more imperative for all growers to show greater visibility, strong fundamentals and continuation of businesses. The platform is ideal for growers to nurture the trust and confidence across the supply chain."

Agrees Raphael Mulinge of Mzurrie Flowers, "IFTEX brings the potential buyers at a single platform wherein they have an access to entire gamut of varieties. The tools of the exhibition is like live demonstration, product launches, touch and feel of the product, networking opportunities, etc., all further foster sales.

In its fifth year, IFTEX has gotten an acceptance in it's role in promoting trade in the sector. This was assured the moment buyers accepted to come in. It was not the same anymore and may never be the same.

What followed was a number of buyers increasing every year. The advent saw a new development to further enhance the productivity of IFTEX; suppliers into the industry joined in and have been increasing by year. The step has catapulted IFTEX to the new levels of excellence. It can now be counted among the major flower trade shows in the world.

Among other benefits, IFTEX provides growers and buyers a face to face meeting point, which is seen as a perfect cost effective means for achieving trade objectives. According to Mr. Shiraz of Agrichemicals Africa Ltd, "The scope of exhibition becomes more important as face to face meetings with target audience provide an opportunity for businesses to meet new buyers in person and also renew their contracts with existing buyers."



Over the last four years, SoliQ Air cartons have redefined the marketplace in bringing **QUALITY, PERFORMANCE** and **SAVINGS** in the supply chain for **FLOWERS**.

An estimated **250 TONS** of airfreight has been **SAVED** resulting in over **EURO 500,000** of savings.

Silpack Industries Limited

- Manufacturer of packaging material based in Likoni Road, Industrial Area, **Nairobi**
- Servicing the East and Central African Region **for more than 30 years**
- Silpack Industries Limited is committed to exceeding the expectations of its customers by:
 1. **Understanding the needs** of the customers
 2. **Innovate** using latest technology and practices
 3. Apply best practices in **"total quality management"**.
- **ISO 9001:2008** certification for Quality Management Standards
- Member of SEDEX and audited for **ethical trade practices**
- Member of Ecodesk for **environmental management** commitments

BillerudKorsnäs

- Provides packaging materials and solutions that **challenge conventional packaging for a sustainable future.**
- We are a **world leading provider** of primary fiber based packaging materials and have **customers in over 100 countries.**
- The company has **8 production units** in Sweden, Finland and the UK and **about 4200 employees in over 13 countries.**
- BillerudKorsnäs has an annual turnover of about **SEK 22 billion (approx. USD 2,7 billion)** and is listed on Nasdaq Stockholm.
www.billerudkorsnas.com

We are doing it again: it is **4 years** SoliQ Air **invented** the **first lightweight performing box** that revolutionized air-freight of flowers and fresh produce. **Get ready** for a groundbreaking re-engineering of SoliQ Air pushing **lightweight beyond any imagination** Official launch at the Naivasha Fair 2016. **SoliQ Air 2.0 – lighter, better, stronger!**



Exceeding Packaging Expectations

Boxes, SFK, Partitions and FlowerSleeves



Amiran

Maxi-boost®

A unique combination of EDTA chelated micro-nutrients with 100% pure natural auxins and cytokinins.



Product Specifications:

Magnesium (Mg) 9,2g/kg	Iron* (Fe) 5,1g/kg
Manganese* (Mn) 2,5g/kg	Zinc* (Zn) 1,5g/kg
Copper* (Cu) 2,6g/kg	Boron (B) 2,5g/kg
Molybdenum (Mo) 0,04g/kg	Sulphur (S) 12,4g/kg
Auxins** 8,6mg/kg	Cytokinins** 0,024mg/kg

*Chelated (EDTA) **Maxi-Boost contains 80% Kelpak

UNIQUE FEATURES OF MAXI-BOOST

Maxi-Boost contains 8.6 mg/l auxins and 0.025 mg/l cytokinins. This is the ideal ratio of 352:1.

The auxins and cytokinins in Kelpak are extracted from fresh *Ecklonia maxima* seaweed, harvested from the Atlantic Ocean of South Africa, by means of a unique patented pressure differential extraction technique which maintains the delicate structure of these hormones.

Consequently, the hormones in Maxi-Boost unlike the traditional sea weed extracts are 100% pure and natural and highly bioavailable for the plant.

Maxi-boost is compatible with most crop protection products.



Old Airport North Rd - Embakasi
P.O. Box 30327-00100, Nairobi
Tel: 0719 095 262 | Email: fert@amirankenya.com

A member of the Balton CP Group of Companies



 Join AmiranK on Facebook

 @amiran_kenya

www.amirankenya.com

Our Knowledge, Your Success.

Sampling Procedures for Testing Water and Fertilizer Solution

This first part will focus on why water and fertilizer solutions should be tested and how to collect samples.

In future editions, we will discuss how to take media and tissue samples and then describe the differences in growing media testing procedures.

Testing water and fertilizer is important as they directly influence the pH and nutrient levels in the growing medium. As a result, they both have a significant impact on crop quality. It is important to periodically test the water to verify that the fertilizer you are using is appropriate for your water and if acid injection is correct or needed. The fertilizer solution analysis verifies that the fertilizer you are using is formulated correctly and also indicates the application rate.

Why Test Your Water?

Testing your water is the single most important test. Consider that the alkalinity of the water (composed mostly of bicarbonates and carbonates) directly affects the pH of the growing medium. Knowing the alkalinity makes it easy to select the proper fertilizer. It makes it possible to determine the fertilizing solution that can offset the pH changing influence of the water alkalinity and to determine if acid injection is necessary and at what rate. The water may also provide sufficient beneficial nutrients such as calcium, magnesium and sulfate, which are often missing from most fertilizers. A disadvantage is that water can also provide high levels of waste elements such as chloride, fluoride and sodium, which can interfere with plant uptake of fertilizer elements. Lastly, water also contains dissolved salts, measured as electrical conductivity (E.C.), which if they are high may mean that frequent leaching of the growing medium is required or the water will have to be treated with a reverse osmosis unit.

“Do you know what is in your water and how it will impact your crops?”

Collecting the Water Sample

When collecting a water sample for testing, it should be taken from the same source that is applied to the crop. If acid is injected, it is best to test the raw water and also the acidified water for comparison. If more than one water source is used to irrigate your crops, then each source should be tested separately. Water should be collected from the spigot or hose end (make sure to flush out stagnant water, fertilizer residues and chemical residues from the hose prior to taking the sample). If unsure, run the water for 2 minutes.

Fill up a clean plastic bottle to the top and leave no air space. Air left in the bottle can alter the pH of the water and have a slight influence on nutrient levels. Most laboratories require anywhere from 4-16



ounces of water for testing. Contact the laboratory and ask for a water test kit. Most laboratories provide the kit free of charge and it includes the appropriate size bottle.

Fertilizer solution sampling

Fertilizer solution should be tested several times per growing season, especially if multiple fertilizers are used. The fertilizer solution can be tested using two different methods: sending a sample off to a laboratory or in-house testing with an electrical conductivity (E.C.) meter. Laboratory testing determines the amount of each fertilizer element in the fertilizer solution and the application rate. This is helpful if you receive pre-mixed fertilizers to verify whether they were properly blended. In-house testing with an E.C. meter can be used to test the fertilizer application rate coming out the end of the hose. In-house testing should be done every time a new batch of fertilizer concentrate is mixed.

“Fertilizer injectors are very reliable for delivering fertilizer to your crops. The fertilizer solution they deliver should be tested to verify whether the nitrogen application rate is correct. Sometimes injectors need maintenance, but mistakes are often made when mixing fertilizer or setting the injection ratio.

Collecting fertilizer solution sample for laboratory testing

Collecting a fertilizer solution sample is similar to collecting a water sample. The fertilizer solution should be collected from the spigot or hose end (make sure to flush out stagnant water, fertilizer residues and chemical residues from the hose prior to taking the sample). It is best to run the irrigation system for 2 minutes to be sure that fertilizer is a thoroughly blended sample. Fill a clean plastic bottle almost all the way to the top and leave some air space. Contact your laboratory and ask for a fertilizer solution analysis test kit. Again, most laboratories require anywhere from 4-16 ounces of fertilizer solution for testing.

It is best to test every new batch of fertilizer with different analyses. This is to verify that the fertilizer formula posted on the packaging closely matches what the fertilizer solution analysis test indicates. This is also very helpful if you blend individual fertilizer elements to make your own fertilizer. Keep in mind that when the injector injects fertilizer into the water line, the fertilizer may not mix uniformly within the water. If so, collect the fertilizer solution coming out the end of the hose in a bucket, mix it and then take the sample.

When you receive the results of a fertilizer solution analysis, note that the designation for phosphorus and potassium in the analysis are not the same as the designation on the fertilizer packaging. Phosphorus is tested as "P", but is listed on the fertilizer bag as P2O5; likewise potassium is tested as "K", but is listed on the fertilizer bag as K2O (see chart below).

Element	Element as tested by laboratory	Element as listed on fertilizer packaging	Conversion factor (ppm as tested by laboratory to ppm as listed on fertilizer packaging)
Nitrate	NO ₃	NO ₃	-
Ammonium	NH ₄	NH ₄	-
Phosphorus	P	P ₂ O ₅	2.29
Potassium	K	K ₂ O	1.20
Calcium	Ca	Ca	-
Magnesium	Mg	Mg	-
Sulfate	S	SO ₄	1.60
Iron	Fe	Fe	-
Manganese	Mn	Mn	-
Copper	Cu	Cu	-
Boron	B	B	-
Zinc	Zn	Zn	-
Molybdenum	Mo	Mo	-

Total nitrogen as listed on the fertilizer packaging is the summation of ammonium, nitrate and urea. Ammonium and nitrate are tested in the same form as listed on the fertilizer packaging. However, urea is not tested unless specifically requested. All other fertilizer elements as seen on the fertilizer solution analysis are expressed the same as on the fertilizer packaging, with possible exception to sulfate.

Below is a listing of the conversion factors when comparing the data from a fertilizer solution analysis with the guaranteed analysis listed on the fertilizer packaging:

Element	Element as tested by laboratory	Element as listed on fertilizer packaging	Conversion factor (ppm as tested by laboratory to ppm as listed on fertilizer packaging)
Nitrate	NO ₃	NO ₃	-
Ammonium	NH ₄	NH ₄	-
Phosphorus	P	P ₂ O ₅	2.29
Potassium	K	K ₂ O	1.20

Using the conversion factors from the chart above, let's use an

example to show how to cross-reference laboratory analyses with the guaranteed analyses on the fertilizer bag. Let's say that we want to verify that 20-10-20 was mixed properly by the manufacturer. A sample of the 20-10-20 fertilizer solution is sent to a laboratory and the analysis of this fertilizer solution shows the results in the table below. Let's convert the laboratory numbers into the numbers represented on the fertilizer packaging: If we add nitrate and ammonium values together, it is equal to 100 ppm nitrogen (60 ppm + 40 ppm), which is also the fertilizer application rate. If we take the ratio N-P-K, then the ratio using the above numbers is 100-50-100. Divide each of the numbers by 5 and we have a ratio of 20-10-20, which is the accurate analysis of the fertilizer.

Therefore, this fertilizer was correctly made by the manufacturer and it is being applied at 100 ppm nitrogen. If the fertilizer contains urea, this is also part of the total nitrogen on the fertilizer packaging and it must be taken into consideration when determining the fertilizer application rate.

Collecting fertilizer solution sample for in-house testing:

In-house testing of the fertilizer solution with an E.C. meter can be used to verify the fertilizer application rate; it will not provide the levels of each nutrient. To collect a fertilizer solution sample, follow the same procedure as above.

To determine the fertilizer application rate, start by calibrating the E.C. meter with a conductivity standard solution. Then test the E.C. of the fertilizer solution coming out the end of the hose. Next, test the E.C. of the water and record the value. Subtract the water E.C. from the fertilizer solution E.C. and this will provide the E.C. of the fertilizer only. Refer to the fertilizer packaging or the manufacturer's website that can cross-reference fertilizer E.C. to ppm nitrogen (see example below).

Example: How much 20-10-20 is being applied as tested below?

E.C. of fertilizer solution = 2.10 mmhos/cm

(minus) - E.C. of water = 0.80 mmhos/cm

E.C. of added fertilizer = 1.30 mmhos/cm (2.10 - 0.80)

Chart used to cross-reference E.C. to ppm nitrogen:

ppm nitrogen	E.C. (mmhos / cm)
50	0.33
100	0.65
150	0.98
200	1.30
250	1.63
300	1.95
350	2.28

"Answer: 200 ppm Nitrogen"

If the fertilizer application rate coming out the end of the hose is not correct, remember that the fertilizer concentrate may have been improperly mixed, the injector may be set at the wrong ratio or the fertilizer injector needs maintenance.

THE WAY TO THE CONSUMER



Within our family of specialised companies in flowers, bouquets and plants, we offer you the way to the international consumer. Florists, through importing wholesale companies or multiple retailers: for every customer world-wide we are cooperating to get the most colourful offer instore.

Our aim is to cooperate in a sustainable way with all parties in the chain, from breeders, growers, logistics to our end customer.

Together we make life more colourful!

For more information, please contact
Jan Smit, tel. +254 20 660800





Hydroponics- The Farming Of The Future?

By Ruth Anita Vaughan

Hydroponics is fancy name for growing plants in soil-less media with a nutrient solution. Humans started dabbling in hydroponics as far back as 1670 when it was discovered that plants grew better in 'dirty' water than in distilled water. Hydroponics became a great way to identify the essential nutrients for plant growth, and the minimum and maximum levels required. Hydroponics gives complete control on nutrient availability.

In Kenya hydroponics is relatively new, becoming popular in the last 15-20 years. The initial move from soil to hydroponics was prompted by the banning of the soil fumigant, methyl bromide, and a general decline in production over time in plants grown in the same soil. It was soon discovered that managed well, hydroponics could be more productive, with better quality and less disease pressure. Hydroponics is generally restricted to high value crops, like roses, but more and more we are seeing tomatoes, capsicum, herbs, leafy vegetables and summer flowers in hydroponics.

Why do hydroponics produce more?

In any growing system the production and quality is determined by limiting factors and pest and disease pressure. Moving into a sterile media removes the pressure from the nematodes and the diseases that had built up in the soil. It also gets rid of the soil problems that can build up over time: - compaction, nutrient in-balance, acidification, lime build up or sodium build up. The biggest improvement to growing in the hydroponics vs. soil is oxygen. Oxygen is the most essential plant nutrient, which we sometimes forget. Hydroponic roots have access to much more oxygen, function better and take up more nutrients, hence the big increases in production. These days it is possible, with a good soil testing laboratory and moisture probe to maximise production in soil.



Yellow leaves in soil grown roses due to oxygen starvation from over-watering – one of the main benefits of hydroponics is increased oxygen levels in the root zone.(a good soil moisture probe will stop this!)

In Kenya, media mainly consists of coco peat, coco fibre, pumice and/or gravel. The media forms a support for the roots, and stops the plants falling over. A nutrient rich solution is dripped through this media, continually refreshing the nutrients in the root zone. Water and the nutrients that are not taken up by the plants drain out the bottom. Plant roots have access to oxygen nearly all the time. The effect of over watering is not felt as strongly as in soil culture because the media drains so easily. The excess water is collected and re-used, hence the dramatic water& fertiliser saving.

The media should be stable, non-compact and inert. Stable, because a media that breaks down quickly would kill the plants. Non-compact, because free drainage is the key to good hydroponics. Inert, because the idea is to feed the plant exactly what it needs via the nutrient system with no contribution from the media. This is the second reason hydroponics can be more productive than soil.

Before use the media should go through a risk assessment. After all, you are investing so much money in a top end system, it would be terrible for the project to fail because of cutting corners. Due to the nature of hydroponics and the movement of the nutrient solutions through the whole system, nematodes and diseases can spread and build up very fast. It is important to start clean and grow clean.

Coco products come from coastal areas and bring with them a risk of high sodium. They should be expanded, soaked in calcium nitrate (calcium is King!) and flushed to remove any sodium. It's a good idea to back this up with a laboratory analysis. Young plants are very susceptible to high sodium and salinity. Coco products are plant materials and can contain nematodes and disease spores. These should be tested in an independent laboratory.

Pumice is a very nice, local, cheap media that Kenya is blessed with. However it too comes with risks. Pumice can have high potassium and other toxic ions. It needs to be tested and flushed. Pumice & gravel can be supplied with a fine silt/dust, which gets into the hydroponic system and cause blockages. Another reason

PACKAGING MATERIALS LTD

P.O. Box 39901 Nairobi, Kenya Tel: 374 5614 Fax: 3745 395 Mob: 0722-524 934 / 0722-377 877 Email: pacmat2002@yahoo.com@gmail.com



PACKAGING TAPES



TAPE DISPENSER



PLASTIC STRAPPING SEALER



STAPLES



GUN PLIER STAPLER



SECATEURS



PLASTIC STRAPPING 15MM FOR MANUAL



GOOGLES



PLASTIC CLIPS



METAL CLIPS



GAS MASKS



POLYTHENE SEALER



PRINTED PLASTIC STRAPPING



RUBBER BANDS



RUBBER GLOVES



RUBBER BANDS



RUBBER GLOVES



PLASTIC STRAPPING 9MM/15MM



DEFOLIATOR BRUSHES -LOCAL



STITCHING WIRE



When you buy from us we offer free service on the strapping & stitching machines

We are proud to be your suppliers of PPE's

Crop Nutrition

for 'washing' it. One problem that we are encountering more and more in our laboratory is nematodes. Pumice & gravel can come from shallow quarries, and already have had plant roots in them. These are associated with nematodes. Get your media tested. If you have nematodes, treat it before use. Solarisation or steaming are good.

Another major fault we see on many farms is the storage of the media before use. Once it's been expanded/sieved/flushed etc., it is often piled up in a corner, uncovered except for a fine crop of weeds. This introduces weed seeds, nematodes, insects, and diseases. Protection of the media is most important.

Feeding your hydroponics

Start at the beginning and get the source water analysed. Because plants take exactly what they need out of the nutrient solution and leave what they don't you can get a rapid build-up of toxic ions: - sodium, chloride, aluminium, boron, & molybdenum. If you have unsuitable water, reverse osmosis or rain water are good solutions. If you have high carbonates, the water can be acidified before use. A high turbidity or organic load from algae also creates problems with blockages and phyto-toxic breakdown products.

Get professional advice for a good recipe. Different crops, different crop stages, different media and water qualities all require different recipes.



AFRICAN HYDROPONICS LTD

Manufacturers of Hydroponics Systems, Computerised Irrigation Systems, Greenhouses, Shade & Insect netting and other Accessories

Save water, fertilizer and environment while ensuring longer and more stems

Use Hydroponics



We also Supply:

- Peval container system designed especially for loose substrate
- PB- inject for control of your Fertilization and is also used to handle the Automatic pH regulation
- Fertilizers and dripline cleaning agents
- Autovent greenhouses and vented crop covers

**Hydroponics**
More gutter and substrate specialist

Alpha Centre No. 83 Mombasa Road,
Box 61310-00200, Nairobi - Kenya.
Cell: 254-733-611458, 0722-305431
Email: info@africanhydroponics.co.ke

**PB techniek**
elektrotechniek
watertechniek
automatisering

Daily/hourly/continual testing of the EC and pH of the drip and drain is very important. A slight change in plant growth due to crop stage, light levels, temperature, humidity etc. can cause a big change to your nutrient solution. Monitor the drip and drain volumes so that the amount of water applied is optimum and the media is getting flushed often enough, but not too much, most farms work on a 20-50% drain. A high EC in the drain than the drip indicates that the plants are just taking up water, and there is a problem somewhere.

Routine laboratory analysis of the drip and the drain should be done at least every 2 months. Some media's are not as inert as we think, and toxic ions can build up- in which case get the media tested as well. Hydroponics is all about fine tuning and nutrient optimisation, so leaf analysis every 6 months and not just when the crop goes yellow is recommended. This allows you to pinpoint any hidden hungers that might be limiting production, but are not obvious when looking at the crop.

The amount and mixture of fertilisers in the A, B and C Tank is critical. Iron can be lost out of your system at this stage, due to high or low pH and UV light. Use

SPECIALISED FIBREGLASS LTD.



The best "insulated bodies in town"

...the best "bodies" in town...



**Tail lifts for
Pallet work.**



**Hold bars with
stainless steel side
and wall plates.**



**East Africa's
First truck
And trailer
Insulated/
refrigerated
body over
56ft long.**

P.O. Box 78201, Nairobi 00507, Kenya, East Africa Phone: +254 (020) 2669524/ 2108640
Cell Phone: 0721 444735 / 0733 915196/ 0739 579907 / 0726 169411 Fax: +254 (020) 2695647
E-mail: sfglass@africaonline.co.ke Web: www.specialisedfibreglass.com

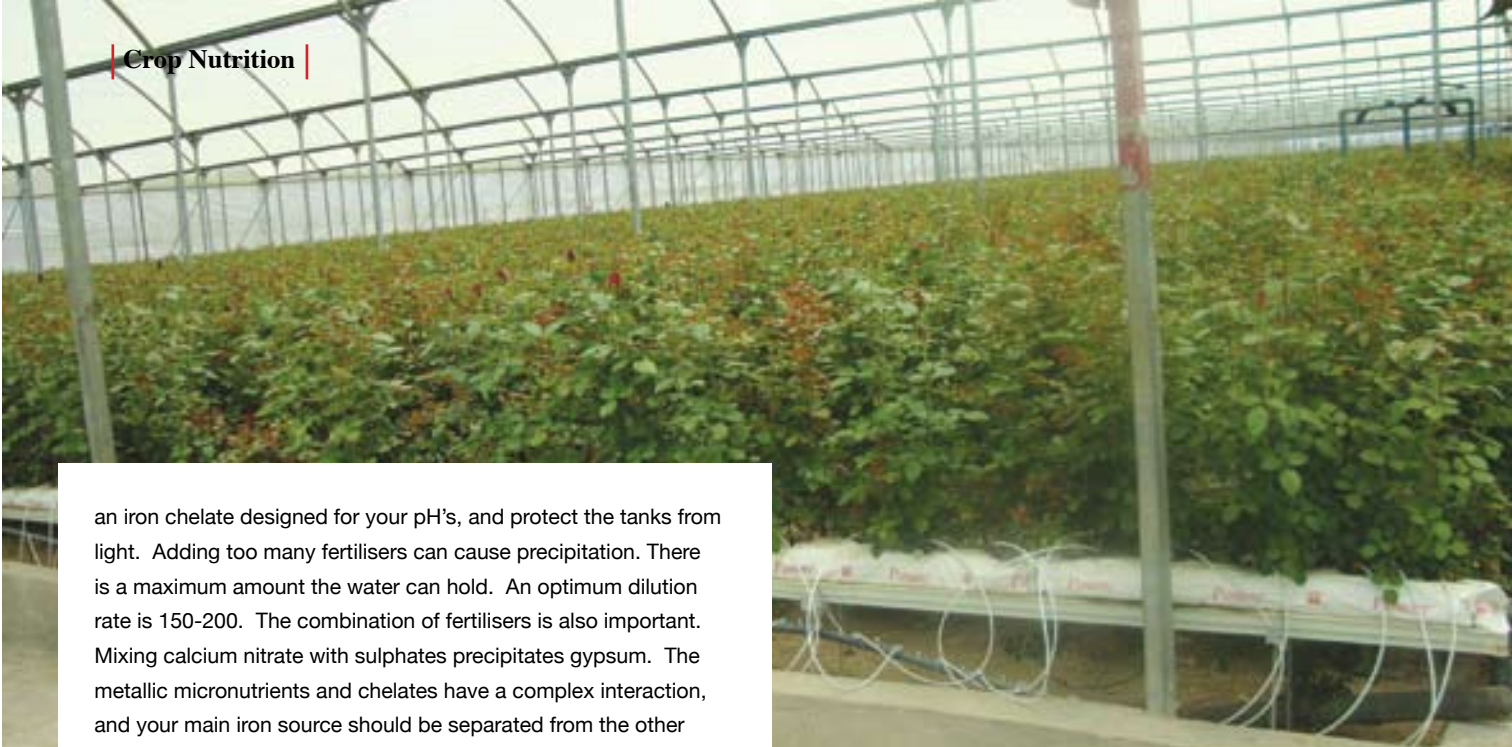

an iron chelate designed for your pH's, and protect the tanks from light. Adding too many fertilisers can cause precipitation. There is a maximum amount the water can hold. An optimum dilution rate is 150-200. The combination of fertilisers is also important. Mixing calcium nitrate with sulphates precipitates gypsum. The metallic micronutrients and chelates have a complex interaction, and your main iron source should be separated from the other micronutrients. When acidifying alkaline water always take into account the nutrient benefit of the nitric or phosphoric acid that you have to add. Fertiliser mixing is a complicated science which is why a drip analysis is so important.

dark colour of the water from the iron chelates. Heat treatment is expensive, energy intensive and only effective with a constant and reliable power source. A slight drop in temperature, and all those nematodes and diseases go back into the system.



Flourishing hydroponic Peas, benefitting from no root disease and nematodes

Re-cycling

One of the main drivers for hydroponics is the environmental benefit due to water saving. If you then release your drain water into the environment, this benefit will not only be lost, but has an even worse effect on the environment than soil culture due to the nutrients in the water that cause eutrophication of the waterways. The water and fertilisers should be recycled. But having passed through all those plant roots, there is a risk of nematodes, diseases, toxic ion build up and nutrient in-balance. Nematodes and diseases can be removed with heat treatment, UV Sterilisation or Ultrafiltration. UV sterilisation is generally not effective due to the

Ultrafiltration is my favourite. It keeps the nutrients in and filters the problems out. It is effective for dark solutions and unstable power. Once the water has been treated it is important to store it in a clean covered tank. Toxic ion build up and nutrient in-balance can be identified and remedied with a water analysis.

Take into account the nutrient content of your re-cycle water. For example if you are using 40% re-cycle water and 60% reverse osmosis water, your feeding regime should be designed on this.

Hydroponics can be so much more rewarding than the soil, but is also less forgiving! A good risk assessment, a proper testing regime, extra knowledge and much closer management are required. Investing into a complete system with no scrimping on equipment, and proper water treatment is essential. The increased production & quality, savings on water and fertilisers, quicker pay back times and environmental benefits, make the higher initial investment worth it.

Ruth Anita Vaughan is the Technical Manager



We offer analytical and advisory services for all your crops needs. Soil, water, plant nutrient analysis, nematode, disease & insect identification, drinking water, effluent water & chemical residue testing, soil mapping, fertiliser recommendations, precision agriculture. ISO/IEC 17025:2005 accredited & NEMA approved.

Crop Nutrition Laboratory Services Ltd, Cooper Centre, Sceptage Rd, Off Watford Way, Newcastle. Tel: +2547216839953, +2547210839953 www.cropnuts.com, Email: support@cropnuts.com

Seit 1887

W. KORDES' SÖHNE



Die schönsten Rosen der Welt
The most beautiful roses of the world
Las rosas mas bonitas del mundo



Kordes-Rose
Madelene®

W. KORDES' SÖHNE

Rosenstrasse 54
D-25365 Sparrieshoop, Germany
Phone: +49 4121 48700
Fax: +49 4121 84745
Internet: <http://www.Kordes-Rosen.com>
Email: Kordes-Rosen@t-online.de

KORDES ROSES EAST AFRICA LTD.

P.O. Box 24581, 00502 Kenya.
Tel: 254-020-2595455, 3008065,
Cellphone: 254-0733-363642, 0722-200643
Fax: 020-2595466
NAIROBI, KENYA
Email: info@kordesroses-ea.com



Tradecorp Discusses Crop Nutrition In Flowers

- Final K - A unique Potassium for high quality flowers
- Calitech - Don't forget Calcium- which is one of the best in the country.
- Phylgreen – anti-stress strategy with the new Tradecorp seaweed range
- Delfan Plus – Unique Amino Acids
- Saltrad – Tradecorp salinity corrector
- Lower 7 - Tradecorp acidifier

Mr. Vincent Claux, the Technical director of Europe and Sub-Saharan Africa

Tradecorp has been helping the flower industry in Kenya for the past 15 years in maximizing yields and plant quality with its superior range of micronutrients & speciality fertilizers. These products are designed to enhance soil health, nutrient availability and fertilizer performance. Founded in 1985 in Spain, the company has a broad experience in crop nutrition.

This was stated by Mr. Vincent Claux, the Technical director of Europe and Sub-Saharan Africa, during a seminar held for flower growers in Kenya in April 2016. During the seminar held in Naivasha, Vincent took the growers through their range of solutions for the sector. "We are a one stop shop for all your nutritional problems", he said. Tradecorp solutions include micronutrients such as Fe, Mn, Zn, Cu, B, Mo, & Co.

Tradecorp Product Range -

- Tradecorp AZ Bentley Plus - A unique combination of chelates for flowers

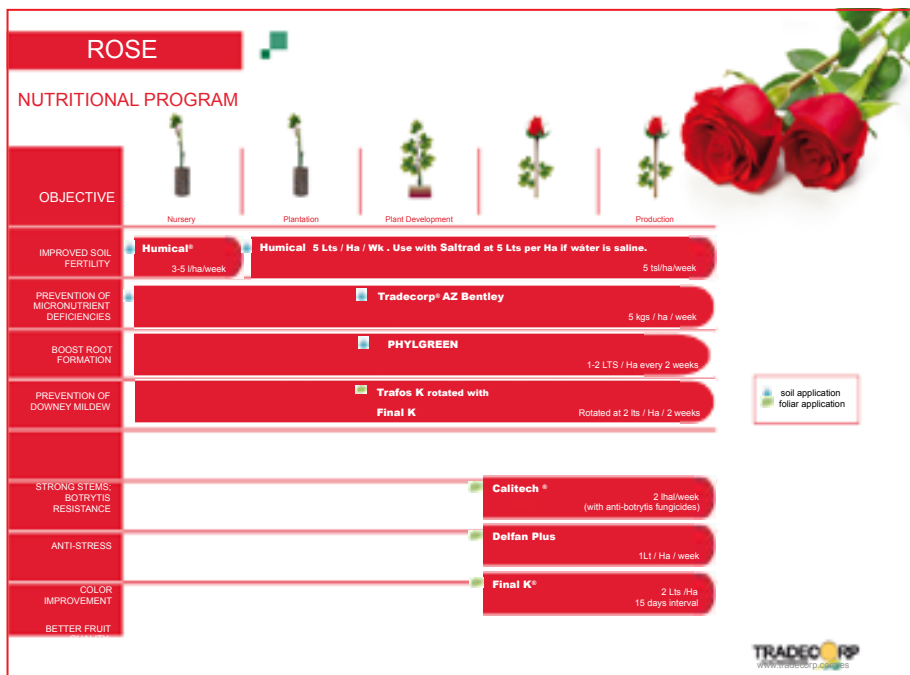

Why Use Micronutrients

Micronutrients are elements essential for plant nutrition and are required in very small (micro) quantities for healthy plant growth, but are vital for metabolic reactions of plants just like vitamins in human beings. These are zinc (Zn), iron (Fe), boron (B), copper



(Cu), manganese (Mn), molybdenum (Mo) and Cobalt (Co). The micronutrients are present in the soil but they are sometimes not available. This is due to soil and nutritive solution pH, soil interactions (clay or organic matter), interactions with other ions present in the soil, interactions with soluble phosphates, low plant uptake, improper irrigation management and climate conditions. In addition, continuous crop cultivation over the years and degradation due to physical factors, results in depletion of micronutrients, affecting the productivity of soil. This leads to deficiency in crops and lowers crop quality and yield.

The company's chelated micronutrients ensure that the products can be administered in a lower dosage and deliver visible results in 48-72 hours. While the chelated products are priced higher than the non-chelated ones, their end-cost of application is lower per hectare as the nutrients are more efficiently absorbed by the plant when administered in chelated form and there is minimal wastage.

Commenting at the launch, Mr Angus Ker, TC Commercial manager East-Africa, said, "The market for agricultural micronutrients is growing. Chelated micronutrients, represent 7 percent of the total regional market by volume and are growing faster than non-chelated ones. Through integration, Tradecorp will be one of the few companies to address the end to end value chain of micronutrients, speciality foliar fertilizers, and soil correctors, thereby bringing consistency to quality as well as pricing with our partner Elgon Kenya Ltd in East Africa. We firmly believe in feeding the plant and not the soil"

In Micronutrients, Vincent took growers through Bentley Plus - a

product with a large pH stability range from 4 to 10, thanks to the combination of EDDHA and EDTA forms. Bentley Plus is the only micromix in the market which offers such "a maximum" insurance factor. In addition, the product is 100% water-soluble and doesn't contain any anti-caking oil. This leaves your tanks and drip lines clean. The micronutrients are fully chelated it has one of the highest chelation rates in the market. Thanks to the excellent Tradecorp technology. The product is a chemical mix, each micro granule has the same composition. This guarantees uniformity and consistency of micronutrients supply to crops unlike physical mixes.

After the launch, Floriculture Magazine spoke to few growers on the products. Mr. Stephen Musyoka of Oserian Development Company Ltd said, "Bentley Plus can be used for all types of applications: foliar, soil, substrates or hydroponics". He added "The product is also compatible with most fertilisers and plant-protection products that are currently in the market". Mr. Vincent said the product is one of the best currently in the market to prevent and correct multiple micronutrient deficiencies in hydroponic crops and in fertigation.

Speaking about this launch Mr. Andrew Tubei of Sian Roses, Masai Farm, stated, "The introduction of Tradecorp products is based on an in-depth understanding of farmers' requirements where there is a clear need for a high quality organic offering in this space. The products have been designed to address this need and enable the grower to efficiently use the products for improving nutrient uptake and crop productivity."

Mr. Vikash Jain of Elgon Kenya Limited, the distributors of Tradecorp products, said they will be undertaking a mass farmer

Role of Bentley plus micronutrients ?

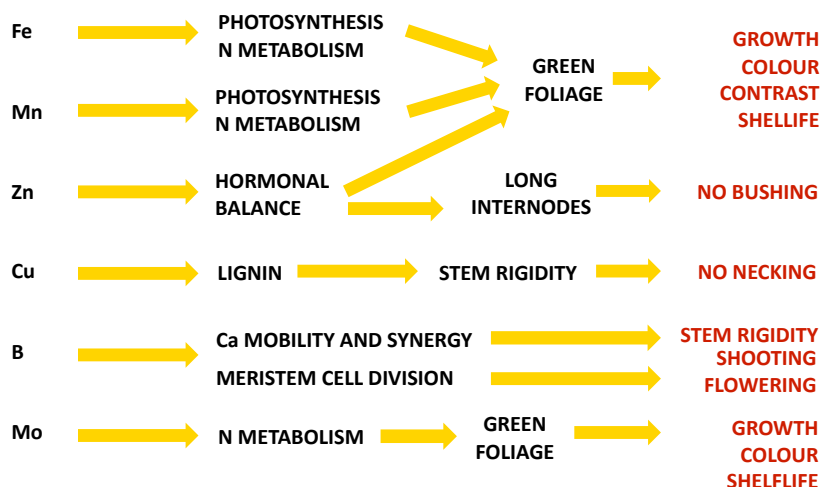

business (crop nutrition & crop protection), industrial chemicals & environment, agro-commodities distribution, logistics and others.

Saptec boasts a Multicultural team, formed of more than 350 professionals. It has local technical teams that offer farmers and distributors a professional, personalized and close service. They are present in the main agricultural markets of the world.

State of the art FACTORIES

The company has tailor made formulations, thanks to the versatility of their factories, that can make formulations to respond to the specific needs of our clients.



awareness programme and farm level demonstrations in key target markets, to explain the key features and benefits of the different range of products, and offering first-hand user experience.

The seminar which followed an earlier one for cereal growers was attended by many flower and vegetable growers from the country. Many of the growers who attended agreed it was a timely forum to educate and discuss the benefits of plant nutrition and expand their choices for the future. As the growers stated, it is key now to improve quality of their produce in an ever competitive global market.

“For more information about Tradecorp products, visit www.tradecorp.co.ke or contact East-Africa manager Angus Ker at aker@tradecorp.saptec.pt”

Who is Tradecorp?

Tradecorp are experts in micronutrients & speciality fertilizers, founded in Spain in 1985. The company has a broad experience in crop nutrition. They strive to be a leading example to both distributors and growers as a producer of innovative speciality products. This is achieved through the commercialization of high quality specialty products and services, which maximize value for their customers. They aim to provide a high quality and professional reference in the micronutrient and specialty fertilizer global market, achieving excellence in service and increasing added value for their customers.

Since 2000, Tradecorp became part of Saptec Group, a company listed on the Brussels Stock Exchange which was established in the mining and chemical sector in 1926. To date, Saptec is an industrial holding company with an extensive portfolio of activities in agro-

chelates. It is one of the few factories in the world capable of synthesizing the chelating agent EDDHA, which they use in the production of Ultraferro. In this factory they produce Ultraferro and Tradecorp AZ Bentley, among others products.

Albacete factory, Albacete, Spain: In this plant they manufacture their ranges of liquid fertilizers and some of their ranges of solid products. In this factory they produce Humistar, Humistar WG, Humical, Trafos Range, Delfan Plus, Final K, Calitech, among other foliar products.

Kilcar Factory, Kilcar, Ireland: In this plant they manufacture their fresh, natural and cold seaweed extract which is used in the formulation of their range of seaweed biostimulants called Phylgreen.

Conclusion

After investing substantial financial inputs, every grower needs a company providing a genuine product range with guaranteed results. Tradecorp is that partner you deserve. Among their maximum priorities is the compliance with REACH regulation, which regulates registration, evaluation, authorization of chemical and fertilizer products, with the objective to guarantee a high level of protection of human health and the environment. Most of their main products are suitable for Organic Agriculture. The company is certificated with ISO 14001 for Environmental Management by the Norwegian entity Det Norske Veritas. They are participants in the United Nations Global Compact, for which they respect and promote the 10 principles established in the areas of human rights, labor rights, environment and anti-corruption. As part of their commitment to the environment and good agricultural practices, they are members of GLOBALGAP.

tradecorp® AZ bentley plus

Simply the best !

TOP QUALITY FOR PROFESSIONAL GROWERS !

pH STABILITY
GUARANTEE: FROM 4 TO 10 !



SYNERGY AND ANTAGONISM BETWEEN NUTRIENTS IN SOILS

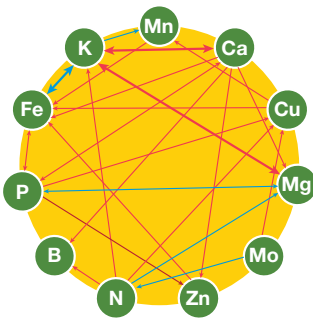

In all soils, especially in sandy soils with high calcium carbonate levels, there are microelement synergies and antagonisms.

Ca has the most damaging effect on many key micro-elements availability for plant uptake.

In sandy soils and hydroponics, there is the added problem of rapid leaching of fertilizers, draining away nutrients before plant utilization.

To counteract this, TRADECORP has developed a unique product that contains the most essential micronutrients including Fe in EDDHA & EDTA forms and Boron

WHY USE tradecorp® AZ bentley plus ?

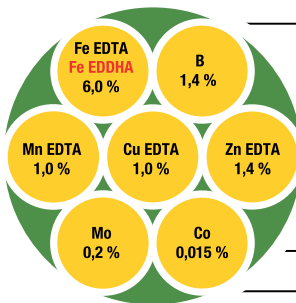

Chemical micro-mix ensuring the homogeneous and regular size and composition of each microgranule

100 % water soluble

Contains all the required micronutrients, fully efficient in a wide range of pH conditions.

Mn, Zn and Cu are chelated with EDTA

Fe is partly chelated with EDTA and EDDHA, the most stable and strong chelating agent

Optimal protection against antagonisms

No anti-dust or anti-caking additives



www.tradecorp.co.ke

Distributed By:
Elgon Kenya Ltd Tel: 020 6534410
Mobile: 0733 69992, 0722203089



Kenya Flower Council

The current KFC membership represents about 70% of the flowers exported from Kenya.



Kenya Flower Council (KFC) is a voluntary association of independent growers and exporters of cut-flowers and ornamentals, formed in 1996, with the aim of fostering responsible and safe production of cut flowers in Kenya with due consideration of workers welfare and protection of the environment.

Against this background the KFC has become a common platform for industry representation, promotion and compliance to pertinent local and international standards, deemed necessary to secure markets.

KFC administers compliance through an internationally accredited KFC Certification Scheme on good agricultural practice, sustainability, social accountability, hygiene health and safety, capacity building, environmental protection and conservation, adherence to which is the backbone of all KFC activities.

The KFC Certification Scheme and Quality Management Systems is accredited by the South African National Accreditation Systems (SANAS), as a Certification Body (C49), in accordance with ISO/IEC 17065.

In order to remain relevant, the Certification Scheme which is a living document stays abreast with industry dynamics. Benchmarking the KFC Certification Scheme to other codes such as GlobalGap, Fair Flowers Fair Plants (FFP), Tesco's Nurture, KS- 1758 in addition to 23 different Kenya Government statutes, provides an opportunity to conduct "Combi" audits as a measure of effective and efficient service to members.

It also embraces the principles of the International Labour Organization (ILO) Convention, International Code of Conduct (ICC), Ethical Trade Initiatives (ETI) and the Horticulture Ethical Business Initiatives.

As of April 2016, KFC had a producer membership of 96 flower farms situated throughout the country. The current KFC membership represents about 70% of the flowers exported from Kenya. Associate

Koppert IPM tools for Flowers



Thrips ✕
Solutions:
• Swirski-Mite (Plus)
• Horiver-TR. (Blue)
• Lurem-TR.
• Attracter

Spider mite ✕
Solutions:
• Spical (Plus)
• Spidex

Mealybug ✕
Solutions:
• Planopar

Whitefly ✕
Solutions:
• Mycotal
• Swirski-Mite (Plus)
• Ercal
• Horiver (Yellow)
• Rollertrap

Maximum disease suppression
Solutions:
• Trianum
• NatuGro concept

Solutions for sustainable crop protection!



KOPPERT
BIOLOGICAL SYSTEMS



Congratulates
Kenya Flower Council
on their 20th anniversary

Koppert Biological Systems (K) Ltd.
Tel: +254 20 2021918 / 4453780/1/2,
WWW.KOPPERT.CO.KE | E-mail: info@koppert.co.ke



KoppertKenya



@KoppertKenya

NATURAL POWER

Contribute to your customers' happiness by consistently using Hicure® on your ornamental crops.

Hicure® is a powerful biostimulant that has been proven to mitigate stress in plants resulting in more vigorous, healthy and high quality flowers with a longer shelf life.



As an associate member of the Kenya Flower Council (KFC), Syngenta East Africa Ltd congratulates KFC on its 20th Anniversary.

We celebrate the continued impact and efforts that KFC has made in promoting sustainable farming practices in the cut-flowers Industry in Kenya.



Hicure®
Biostimulant

syngenta®

Hicure® is a registered trademark of a Syngenta Group Company. Syngenta East Africa Ltd.,
P.O. Box 30393, 00100 Nairobi, Kenya. M: +254 703 018 000, +254 703 019 000, +254 733 622 788
E-mail: syngenta.east_africa@syngenta.com | www.syngenta.co.ke

TM

membership stands at 69 members representing major Cut Flower Auctions and distributors in UK, Holland, Switzerland, Germany and Kenya. Associate members are involved in the flower sector through flower imports, provision of farm inputs and other affiliated services.

Kenya's horticultural sector currently ranks as one of the economy's fastest growing industries, the third largest foreign exchange earner after tourism and tea, a trend that saw the industry rise to approximately 40% for the past ten years with total exports reaching 220,000 tonnes in 2014.

The history of the export of fresh horticultural produce from Kenya dates back to the period before independence when Kenya, then a British colony, was required to contribute to the running of the budget for East Africa. After independence the industry continued to flourish with exports starting to go to Europe and thus opening up the potential for Kenya in the export market.

Overall exports to the European market started to increase in the 1970's with the Netherlands being the largest importer, taking a 71 per cent share by volume, with most distributed through the auction system. Next came the United Kingdom on 20 per cent, followed by Germany on 6 per cent. Success can be attributed to Kenya's ability to provide high quality products on a year-round basis, backed by daily airfreight arrivals to key destinations.

KFC is a member of:

1. Global Gap
2. Floriculture Sustainability Initiative (FSI)



Flight -ace personal



From Kenya to the world:
We take personal care of your cargo.
Now, and in the future.

3. Union Fleurs
4. COLEACP
5. Kenya Horticultural Council (KHC)
6. Horticulture Council of Africa (HCA)
7. Kenya Private Sector Alliance (KEPSA)
8. Kenya Association of Manufacturers (KAM)
9. Federation of Kenya Employers (FKE)
10. National Taskforce on Horticulture.

THE VISION

"To be the lead organization in the provision of representational, self-regulation and promotion services for the floriculture

industry in Kenya."

STRATEGY

"Active participation in the formulation and implementation of policies governing sustainable development of the floriculture sector".

THE MISSION

"To promote economic, social and political interests of the floriculture industry through active participation in the determination and implementation of policies governing sustainable development of the sector".

Making Progress, Driving Change



We are living in a world where temperatures are rising; water is scarce, energy expensive, food supplies uncertain and the gap between rich and poor increasing.

We cannot close our eyes to the problems the world faces. At Agrichem Africa Limited® we believe that business must be part of the solution. But to be so, business will have to change. Sustainable, equitable growth is the only acceptable business model.

Agrichem Africa Limited® works to create a better future every day, with brands and services that help people feel good, look good and get more yields out of the harvest. Our first priority is to our consumers – then farmers, employees, suppliers and communities. When we fulfil our responsibilities to them, we believe that our shareholders will be rewarded.

Agrichem Africa Limited® has, from its origins, been a purpose-driven company. Today our purpose is to make sustainable farming a common activity. This means helping to build an industry where everyone lives well and within the natural limits of the planet:

- Brands that offer balanced nutrition, good yield and the confidence that comes from having even more when it comes to farming for both the Floriculture and Horticulture sector.
- Products which are sustainably sourced and used in a way that protects end user who is in this case the farmer and the earth's natural resources at large



- Respect for the rights of the people and communities we work with throughout the world.

Our new global initiative will lead for responsible growth which aims by inspiring to motivate millions of people to live sustainably by taking small, everyday actions that make a big difference to the world. Agrichem Africa Limited® will grow by winning shares and building markets everywhere.

Agrichem Africa Limited® is already seeing the results of our efforts. Our focus on sustainability is driving brand growth, competitive advantage and differentiation.

The virtuous circle of growth describes how we generate profit from our sustainable growth business model.

Brands that are integrating sustainable living into their core purpose are driving success for our business. Our growing range of sustainable products is also helping drive growth with our retail partners.

By looking at product development, sourcing and manufacturing through a sustainability lens, opportunities for innovation open up. By collaborating with partners in products manufacturing and supply chain organizations, we can leverage skills, capabilities and networks that we do not have.

We have avoided cumulative production costs of over the years through more efficient manufacturing. Agrichem Africa Limited® plan is inspiring our employees to act. One example is by encouraging staff to

develop sustainable business ideas. These yields an average payback time of less than two years and have helped us achieve big reduction.

Working closely with packaging technology experts, we have developed a technique which allows major savings through this technology after being fully applied across our portfolio of products of which upon implementation this technology has delivered major cost savings.

Over the past years they have been years of good performance. We have found we are able to make excellent progress

on the targets within our direct control. Those outside our control are proving more challenging. This has been a success since Agrichem Africa Limited® has helped majority of farmers improve their cultivation progress which was a target towards our ambitious target among most brands gaining market share and growth in sales.

In partnership with our manufacturers and suppliers we have provided help and training to farmers. We plan to deepen this engagement to ensure it feeds through to a positive impact on their farming experience and livelihoods. Our door-to-door selling operation provides work for large numbers of technical sales representatives in different areas. This grows our business and improves by impacting positive output in the lives of many farmers, often doubling their harvest yield.

Our supplier and distribution networks across the Africa region and the world at large involve majority of smallholder farmers, small-scale distributors and retailers. We contribute to their economic well-being by creating employment, improving skills and offering access to markets. This can, in particular, benefit young people who have borne the impact of the slowdown in the global economy.

Agrichem Africa Limited® main goal is to have a positive impact on the lives of many farmers as possible and the entire society at large by improving the livelihoods of smallholder farmers, improving the incomes of small-scale retailers and increasing the participation of young entrepreneurs in our value chain. Our approach is to engage with smallholder farmers to improve their capability and productivity, focusing on key crops in the Horticulture and Floriculture Sector. We also plan to expand opportunities for micro-entrepreneurs in the distribution and retailing of our brands. This will grow the markets for our products

| Company Profile |

and make our business more resilient in an uncertain world.

We have set a bold ambition to achieve change within our own company – through our brands, innovation, sourcing and operations. But we are only one company among many and the change needed to tackle the world's major social, environmental and economic issues is big – and urgent. What are really needed are changes to the broader systems of which we are a part.

We have decided to deepen our efforts in key areas where we have the scale, influence and resources to create 'transformational change'. By that we mean fundamental change to whole systems, not simply incremental improvements by championing sustainable agriculture and the development of smallholder farmers. Going beyond what we can achieve in our own operations and with our suppliers, we are stepping up our engagement to work

with governments, NGOs and others in our industry on these issues. By working together, we believe that fundamental change is possible in the near term.

Rising populations, climate change, water scarcity and unsustainable farming practices are threatening food security. In developing countries three out of four people depend on agriculture for their livelihoods. That makes sustainable agriculture a strategic priority for us by engaging with at smallholder farmers to improve their livelihoods.

Agrichem Africa Limited® open-source Agriculture Code has not only been used by our own suppliers, it has inspired and set a benchmark for other companies and organizations, catalyzing broader change. We are also playing a leading role in transforming the tea industry, working with a range of partners in the manufacturing industry and global supply chain

certification bodies to achieve fundamental change in farming practices.

Uniquely, Agrichem Africa Limited® has leading brands that can make a difference in the Agriculture Sector. We are exploring how we can focus our efforts and engage even more with others. Already we are changing farming behavior at scale. Innovative farming, crop care and protection have assisted to achieve better yield outcomes and lower costs.

Agrichem Africa Limited® has found that doing business sustainably is possible and that brands that build sustainability into their offer can be more appealing to consumers. We realize that we can make a bigger difference to some of the world's major social, environmental and economic issues if we leverage our scale, influence and resources to drive transformational change. We cannot achieve our vision alone.





Your Partner in Agriculture

DEALERS IN AGROCHEMICALS FERTILIZERS FI
HYBRID SEEDS GREENHOUSE IMPORTED POLYTHENE
(FILMS) SHEETING AND GREENHOUSE STRUCTURES

For more information please visit our offices or contact our sales team at
WINSFORD PARK OFF BABA DOGO ROAD RUARAKA

P O BOX 27151 G P O 00100 NAIROBI KENYA

PILOT LINES +254 733 806 200 +254 727 531 010

+254 720 325 144 +254 20 2642115

E-MAIL marketing@agrichemafrika.com

**AGRICHEM AFRICA LIMITED®
IS A REPUTABLE SUPPLIER OF
FUNGICIDES TO FLORICULTURE
FARMS FOR CONTROL OF
POWDERY MILDEW IN ROSES**

**SULPHUR GOLD 80%WDG
WETTABLE GRANULES
SULPHUR 800G/KG**

A preventative contact sulphur fungicide with a broad spectrum of activity that has a specific action against Powdery Mildew in Roses. SULPHUR GOLD 80%WDG® stimulates plant growth and development of a healthy plant by increased photosynthesis when applied as a foliar spray prophylactically.





5377 parlormarketing.co.uk

Impressive rewards
from BASF solutions

Meltatox[®]

Good powdery mildew control for over 30 years

- Long lasting protection
- Best anti-sporulant fungicide
- Excellent curative action
- Offers good resistance management
- Easy to use
- Quick re-entry possible (worker safety)
- IPM compatible

Collis[®]

Reliable performance against powdery mildew

- Controls powdery mildew
- Great disease prevention performance
- A good mixing partner
- IPM compatible
- Quick re-entry possible (worker safety)

BASF East Africa Ltd
Tel: +254204443454 - 56

Joseph Maina
Ornamentals Manager-Kenya
joseph.muita@basf.com
Mobile:+254 786 856973

 **BASF**
The Chemical Company

Paving the way for Food Security Leads

Matt Fryer

To The Helm Of Arysta LifeScience East Africa

Briefly discuss Matt Fryer (Background and Managing Director Arysta LifeScience East Africa)

I was born into a farming community in South Africa, and my love for farming, nature and the outdoors started as far back as I can remember.

After completing my BSC Agric in 2002, I went on to work for a small crop protection company, Gap Chemicals, based in Kwazulu Natal and focused on Sugarcane. The small size of the company resulted in me being exposed to all aspects of running a successful business and this quickly revealed yet another passion I have for customer service.

In 2008 I joined Arysta LifeScience South Africa as a Key Account Manager and in addition to my deliverables I took on active roles in the S&OP process, demand planning and had a short stint of looking after the Southern Africa export business. In 2014 I was appointed Commercial Manager for South Africa, mainly as a support role to the Commercial Director, and was responsible for forecasting, pricing, stock distribution and allocation. In early 2015 I was offered the incredible opportunity to move to Nairobi. Having spent my entire career being based in South Africa, it was an easy decision to make to move here and embark on this new leadership challenge.

How would you describe your first year as the Head of Arysta Lifescience East Africa? Are you passionate about what you do?

The first year as Head of East Africa has been exciting, challenging and rewarding. I see East Africa having tremendous potential, but to achieve self-sufficiency and realise this potential, food security needs to be at the top of government's agenda and from what I've seen so far, it is. I'm very passionate and proud about being part of the solution in delivering food security to the region.

Moving to a new country and market can be daunting, but I was fortunate enough to be joining a very welcoming and professional team. They really helped make the transition a smooth one. To make matters more challenging we were faced with the purchase and integration of Arysta, Chemtura and Agriphar into one entity. With the hard work and commitment of the team, not only did the integration go seamlessly but we were able to still achieve a 100% growth rate in 2015.

Year one was focused on improving our operating systems, making sure back office functions supported the business growth and consolidating and optimising the team on the ground. We achieved this and at the same time successfully integrated the three legacy companies into one face to the customer.

In order to support the growth process that the region committed to, the Eastern Africa management team leveraged best practice from southern Africa and set up the 1st Strategic Agenda workshop in early 2016. Sixteen members of the East African team met in the Nairobi office to embrace the challenge. The Strategic Agenda will be our road map to achieving the 2016 Financial Targets, and at the same time being compliant and looking after the interests of our customers, the organisation, our employees, neighbouring communities and the environment. In this process, we identified key initiatives that need to be implemented to ensure short term targets are met, while remaining sustainable in the long term.

What is your vision for Arysta Lifescience East Africa?

Arysta LifeScience has a very strong presence in Africa and is recognized as the market leader in Southern and West Africa. Our positions in South and West Africa resulted from significant acquisitions and then subsequent organic growth. East Africa is the exception and our growth was started from a low base and relied on organic growth, that was until last year and the acquisitions of Chemtura and Agriphar. Although our footprint is still relatively small, we have increased our team from 19 people in 2014 to the current team of 35 and have more than doubled our revenue over the same period.

Our vision for East Africa is to be recognized as one of the leading Crop Protection companies, with an emphasis on customer service and product stewardship.

What are your top priorities?

We have both short and long-term priorities. The short term priorities include continuous improvement of processes and procedures, updating our operating systems and to maintain a motivated and empowered team that is passionate about the business and the industry they work in. We pride ourselves on customer service and this will always be a top priority.

The long term priority is to remain at the forefront of technology and make sure our products and services remain relevant and up to date with the industry.

In a nutshell describe Arysta Lifescience East Africa products and services to the farmers

To ensure our short term growth our focus has been on bringing new registrations to the market, maximizing the sales and distribution of our existing range and 3rd party product distribution on behalf of



the greatest area of land farmed in the region. Small scale farmers are becoming more sophisticated and technically astute, and they are demanding the latest technology to improve their yields and we intend to remain part of their solution.

As part of the Chemtura acquisition, we now have a range of seed treatment products in the region and updating this range will be a priority in the future. We also distribute Public Health products in the region for Syngenta, focused on Malaria vector control.

Briefly discuss the Arysta Lifescience East Africa team

Arysta Lifescience East Africa has a professional, qualified and experienced team that are passionate about what they do. I am very pleased with the team we have on the ground and the management team. We have plans to expand the team even further and last month we employed an R&D Manager in Ethiopia. We have identified this country as a key market for future growth.

We have offices in Dar es Salaam, Nairobi and opened an office in Addis Ababa in 2015. We also service Rwanda, Burundi and Uganda from Nairobi.

Lately we have seen a more aggressive Arysta Lifescience East Africa, what can you attribute this to?

Two years ago Arysta Lifescience embarked on a 5 year growth plan in East Africa. It identified key factors to be implemented in order to secure our planned growth in the region. Arysta's global acquisitions of GBM and Goemar gave us a head start in the biosolution and crop nutrition space. Unfortunately this market is not regulated and there are so many products being marketed in this space that do not deliver the promised results and have gone some way in tarnishing the image of this group of products. However, our products are backed up by global and local scientific data along with replicated trials showing significant yield increases.

With these products plus the acquisition

multinationals and J Makers. We have a balanced range of products catering for all market segments.

Large scale commercial farmers in the row crop and ornamentals sectors have been using our products such as Evisect, Silwet, Levo, Kalach, Floramite, Sigma Combi, Satunil, Proplant and Orthene for a number of years and these are well known and established brands. Recently we introduced new active ingredients to the market such as Teppeki (flonicamid), which is a very effective insecticide with a good IPM profile and Topcane (amicarbazone) which is a pre and post emergence herbicide for long term residual weed control in sugarcane. These products are distributed and serviced by our key partners, but at the same time we have on the ground presence to ensure product stewardship and to create additional demand.

In late 2014, we appointed a new Retail Market team, under the leadership of Patrick Amuyunzu. Products such as Cuprocaffaro, Kalach, Orthene, and Folimat are important products in this segment. This is an area of the business that we will continue to invest in as the small scale sector represents



of Chemtura, Agriphar and Arysta by PSP, the growth plan is delivering the results and justifying further investment in the territory. We now have a greater product range, more experienced staff and improved capacity to transact with big customers.

Are you intending to expand your products range and market, what factors that are you considering in making that choice?

Yes, we have a very active R&D pipeline and are always looking for new molecules to develop and register as well as being the preferred distributor for 3rd party products.

The most critical factors when choosing products to develop in-house is their long term future, customer needs and to fill the gaps in our product range. We cannot afford to invest in products with a limited shelf-life due to factors such as product toxicities and pending molecules limitations.

Where do you think the most significant growth will occur in the company in the next few years? What new competition are you expecting then?

I think the most significant growth will come from the newly entered markets like Ethiopia, and especially in the Biosolutions space. The greatest competition and threat will come from new market entrants that have no investment in the countries, questionable registration data, low operating costs, no product training and support and the only service they offer is low price. Although these businesses have proven to be unsustainable, they disrupt the market and drive down prices. Some

farmers see this as a benefit, but cheap products often come at a price. Crop Protection accounts for +/-5% of a farmers input costs, but a mistake can cost him 100% of his yield. Unfortunately this risk is often overlooked when a purchase decision is made.

What's the biggest challenge YOU feel your company faces, and how do you inspire your employees to meet it head on?

One of the biggest challenges we face is internal change in our organization. We have had 3 owners in the past 8 years and with that comes new cultures, expectations, ways of working, reporting lines and structures. Another challenge is to have balanced growth and sticking to good business practices. The lure of an easy sale is often followed by debt problems, a sale in not complete until the money is in the bank!

One of my only disappointments since moving to East Africa has been experiencing a culture of non-payment of debt. This has definitely been one of our growing pains and lessons have been learnt. We have now consolidated our customer base and will only work with reputable and reliable customers in the future. I continuously remind the team to embrace change and remain motivated.

Lately we have seen numerous acquisitions and mergers globally. Where do you see the agrochemical sector globally in the next 5 and 10 years from now? How are you prepared for this change in the industry?

One thing I have learnt at Arysta Lifescience since joining the company is that change is inevitable and learned to embrace it. Arysta Lifescience

has already been through a number of acquisitions and mergers so I expect this to be the pattern in the future. "Bigger is better" seems to be the global trend in all industries and Crop Protection Industry is no exception. I expect this trend to continue as history has a tendency to repeat itself.

There is always opportunity in these acquisitions and mergers. New entities are often required to divest in products due to competition laws and Arysta Lifescience should be well positioned to invest in these products if the opportunity arises. Larger companies are often slower to react to market changes and decisions take a long time to be rubber stamped. There has always been a spirit of entrepreneurship in Arysta Lifescience and this culture empowers local leadership to make local decisions that will improve their business. If we are able to maintain this culture, then the future will remain bright for us.

What is your personal work ethic, and how does this affect the company culture?

I like to have processes and procedures in place and am generally systematic in the way I approach things. When a company starts off small and experiences fast growth, it is often processes and procedures

decision and run with it.

Discuss the most pivotal moments in your career that you either learned from and/or that got you where you are?

I would say that starting off my career in a small company and being exposed to all aspects of running a successful business was critical to laying a solid foundation for my future growth. Another quality that I learnt during my career is to back yourself and to put up your hand when it comes to taking on new challenges and additional responsibility. Hard work pays off and if you deliver results, you get noticed and recognized. People that sit in the back corners of the office, who are not willing to participate or move out of their comfort zones do not get recognized.

Describe your ordinary day? Do you have enough personal time?

I had to commute between South Africa and Kenya for the first 9 months due to work permit delays and this was quite tough on my personal life as I was away from my amazing wife and children for up to 2 weeks at a time. Now that we are based in Nairobi, the family is a lot more settled and happy.

I generally wake up at 6am and leave for the office at 7am. I am

fortunate enough to have a driver so I use the time in the car to catch up on emails and plan my day. Most days are spent in the office or meeting with customers and suppliers in and around Nairobi. In future I plan to spend a lot more time in the field visiting customers to hear first-hand what challenges they face, the direction that various industries are moving in and to assist where I can. I try leave the office by 4pm to avoid peak hour traffic. Again I use this time to catch up on emails and attend conference calls. I have two young children and by getting home by 5pm, it gives me time to spend with them before bed time. It is important to have a balance between work and personal life, but often it is work that takes priority. As they say, "a happy

wife, is a happy life" so it is critical to have that balance between. I have an understanding family who support me unconditionally and I'm very grateful for that.

Give your final comments

I have really enjoyed my time so far in East Africa and it has given me a much greater perspective on agriculture in Africa. Coming from South Africa which is dominated by large commercial farms, it is great to see the level of expertise and sophistication of the small scale farmers in East Africa. Food and water security is becoming more and more challenging due to climate change and a growing population. Farmers need to produce greater yields per unit land to feed the expanding population and being part of the solution by giving farmers the tools to protect their crops and increase yields is a very fulfilling experience.



that are overlooked. Once these are in place, then my personal leadership style is to empower management to make decisions.

I do not like to micro manage people as there are more important strategic considerations to focus on. I have an open door policy and a good working relationship with the team. I'm very open to new ideas as long as they have been well thought through and make financial sense.

What decisions have you made in your career that you look back on and feel were mistakes, and what have you learned from them?

I have no real regrets in my working career to date. The one lesson I have learnt is not to procrastinate on making the right decisions. Go with your gut feel and don't over analyse every situation, make a

MEGAFOL

PROTECTS FROM THE HARDEST BLOWS



ANTI-STRESS ACTIVITY

Keeps plant vigor in adverse environmental growth conditions.

GROWTH ACTIVATOR

In absence of abiotic stresses it promotes the growth and development of the plants.

CARRIER ACTION

Improves foliar absorption and effectiveness of the products mixed together.



MEGAFOL[®] is a bio-stimulant based on plant extracts and produced with the specific and unique GeaPower technology process named GEA 931. MEGAFOL[®] improves and optimizes the growth and development of crops and helps to overcome reduced growth due to adverse environmental conditions. Valagro is committed to offering innovative and effective solutions for nutrition and plant care, respect for people and the environment. www.valagro.com

 **Valagro**[®]
Where science serves nature

Ethiopia's Horti Export Shows 17% Increase



Ethiopia's horticulture sector has generated more than USD 185 million in just eight months, showing a 17 per cent increase compared against the performance same period last year, according to Ethiopian Horticulture Development Agency (EHDA).

Cut flower export to Europe takes the biggest share of the revenue obtained in the reported period generating over USD 150 million. "We managed to obtain USD 151.06 million from flower export which is 71.98 per cent of the USD 209.86 million targeted revenue for the period," said Alem Woldegerima, Director General of the agency during an interview with ENA.

Export earnings from vegetables hit USD 30 million while fruits generated USD 3.6 million, according to the director general.

Despite improvements in revenue as compared to same period last year, Alem said EHDA along with regional bureaus and other stakeholders is engaging in

integrated works to increase the capacity of revenue generation which also includes series of supports and follow up activities on investors engaged in the field.

The director general attributed limitations in providing land and low appetite in the global market for the decrease in revenue targeted for the period. He mentioned joint activities with the Ministry of Foreign Affairs and ongoing efforts to provide investors with lands to raise revenue generated from the sector.

Attracting new entrants to the field can also be possible through providing plots of land furnished with required infrastructures, according to Alem.

Future focus areas of the agency will include increasing supply of lands, establishing integrated work between federal and regional states as well as follow up and supervision activities on investors provided with lands but who fail to launch projects as per schedule.

Rwandan Flowers Reach International Markets

The cultivation of flowers could soon become a vibrant new sector in Rwandan agriculture. It is a great opportunity for local farmers, floriculture investors and the country's economy.

It is in this year that exporters of flowers have expanded their activities to the regional and Europe markets.

With the support of the National Agricultural Export Development Board (NAEB), these exporters have managed to secure some floriculture business deals after lands for production were availed in the country. NAEB has also facilitated them to get packaging materials as well as other technical assistance to make the sector viable.

The variety of flowers being sourced from the Northern Province, Kigali City and some from the Southern Province are the result of improved planting materials imported by NAEB which were also distributed to five out-growers in the end of last year.

NAEB needs competitive investors to uphold the projects in place and to eye more opportunities still available.

This year, the country has put in place initiatives to promote Made-In-Rwanda products abroad, and along with Coffee and Tea, NAEB is aiming at increasing the production of flowers, its awareness, and is seeking for more investors with sustainable market and capacities.

Source: www.naeb.gov.rw

Chrysal has the Answer against Ethylene

AVB + AVB Booster

Chrysal AVB

Chrysal AVB is a post-harvest conditioner for ethylene sensitive summer flowers. Dependent on the flower type the positive effect may manifest itself by an improved vase life, a diminished dropping of blooms, leaves and buds and an improved bud opening.

The active ingredient in Chrysal AVB is silver for which Chrysal developed a neutralization method based on the use of Chrysal Tecitine and Chrysal Flocculine. This way most silver can be recovered prior to the disposal of any waste solution.

Vase life Alstroemeria



Treatment: water

Total vase life: 13 days

Treatment: Chrysal AVB

Total vase life: 19 days

Vase life Dianthus



Treatment: water

Total vase life: 5 days

Treatment: Chrysal AVB + Booster

Total vase life: 16 days

The Beauty of Chrysal



NEW FORMULATION OF

Chrysal AVB Booster



Chrysal AVB Booster improves the performance of post-harvest conditioner Chrysal AVB. It stimulates the water and silver (STS) uptake. Especially effective for ethylene sensitive summer flowers, like carnations and dendrobium.

Herewith we inform you about a change in the dosing of our **Chrysal AVB Booster** from 0,5ml per liter to **1ml per liter**.

This change to the concentration brings the product in line with most other Chrysal post-harvest products. The increase in dosing will have an improving effect on the stability of the concentrated product.

Vaslife Dianthus mixed

Fresh pre-treatment solution

Photo's taken: day 9 consumer phase

WATER



Used pre-treatment solution (4 days old)

Photo's taken: day 9 consumer phase

WATER



Chrysal AVB + Chrysal AVB Booster



Chrysal AVB + Chrysal AVB Booster



Floral Sales Give UK Supermarkets A Boost

Cut flowers have increased by 7 per cent; helping fruit and vegetable revenues to grow by 4 per cent despite like-for-like produce prices falling.



Supermarket sales in the UK have enjoyed their fastest rate of growth since October 2015, aided by strong fresh produce and flower sales.

Despite this, the market is still being held back by the ongoing price war and falling grocery prices, which are down by 1.6 per cent — a continuous decline which began in September 2014.

Fraser McKeivitt, head of retail and consumer insight at Kantar Worldpanel, said: “Despite prices continuing to decline, the combination of Valentine’s Day, and consumers stocking up for an early Easter has boosted certain categories. Cut flowers have increased by 7 per cent; New

Year resolutions to eat more healthily don’t seem to have been forgotten, helping fruit and vegetable revenues to grow by 4 per cent despite like-for-like produce prices falling.”

Across the main retailers, Sainsbury’s was again the only one of the ‘big four’ to increase overall spend. Sales grew for the eighth period in a row, up by 0.5 per cent - the longest run of sales growth for any of the four main retailers since March 2013. The grocer has been boosted by strong online sales and its Sainsbury’s Local convenience stores, though its overall share remained flat at 16.8 per cent. McKeivitt added: “Tesco’s positive run continues as its overall sales fell by 0.8 per cent - halving last month’s decline of 1.6 per cent. A renewed focus on

price promotions has helped stem the flow of shoppers leaving the retailer despite the closure of around 50 stores in the last year.

“Morrisons is also operating fewer stores than last year, which continues to contribute to its falling sales - this month down by 3.2 per cent, with its market share dipping to 10.6 per cent. Online, Morrisons’ sales are growing strongly, a trend set to continue in the coming months as the retailer converts more existing in-store shoppers to its e-commerce channel. Despite being a relative latecomer to online grocery, Morrisons’ forthcoming tie-up with Amazon could provide another boost to the business.”

Compared with the 0.5 per cent growth in the overall market, sales in larger stores have fallen by 2 per cent as consumers spend less per average trip in these shop formats. This has disproportionately affected Asda with its large stores, with sales falling by 4 per cent and market share down to 16.2 per cent.

Waitrose saw sales grow by 0.2 per cent, maintaining its 5.2 per cent share of the market for the third period in a row. Across the smaller retailers, market share gains were made by The Co-operative, Aldi and Lidl. The discounters’ combined share, meanwhile, climbed back to the 10 per cent high they reached before Christmas. Lidl’s sales grew by 18.9 per cent, and Aldi’s by 15.1 per cent.

TWIGA CHEMICAL INDUSTRIES LTD

Providing Solutions for Downy Mildew...



Downy Mildew

FANTIC

(Benalaxy M 40g/kg and Mancozeb 650g/kg)

Features

- Excellent preventative and curative action
- Efficacy at low doses
- Long-lasting preventative activity
- Rain Fastness
- Immediate action / rapid penetration
- Uniform distribution through the plant
- Secondary efficacy on other diseases

ALIAL

(FOSETYL - ALUMINIUM 80% WP)

Features

- Wide spectrum of control
- Multi site mode of action
- Versatile in application
- Safe to the environment
- Long persistence on the crop

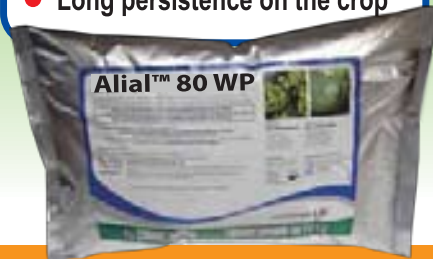

When high quality and high yield matters ...

codamin radicular

The biostimulant that delivers it all to help flower growers meet qualitative and quantitative demands of the flower market

BENEFITS

- Increased bud/head size - better prices
- Increased stem length by up to 5 cms
- More sellable Stems, increased revenue to growers
- Reduces crop cycle/flush by 5-7 days;
- Increased number of stems per sq. meter
- Improved post harvest shelf life - less loss incurred



DISTRIBUTED BY: Twiga Chemical Industries Ltd.

Nanyuki Road, Industrial Area, P.O. Box 30172, 00100 GPO, Nairobi, Kenya. Tel: +254 (020) 3942100 /3942000,
Fax: +254 (020) 3942405, Email: info@twiga-chem.com Website: www.twigachemicals.com

REPUBLIC OF KENYA



MINISTRY OF AGRICULTURE, LIVESTOCK AND FISHERIES

Radeecal
communications



Agritec Africa



International
Exhibition and
Conference



June **15** **16** **17** 2016

Kenyatta International Convention
Center, Nairobi, Kenya

Explore the **Most Emerging Market** in the Globe

HIGHLIGHTS OF Agritec Africa 2015

**Book
Your
Stall**

Exhibitors from following countries



Kenya



India



China



Pakistan



U.A.E.



Saudi Arabia

**Participating
Companies**



**Total No.
of Visitors**



Visitors from following countries

Kenya, Tanzania, Sudan, Zambia, Rwanda, Congo,
Burundi, Nigeria, Ethiopia, Egypt, Uganda, Ghana,
Malawi, Italy, U.K., Switzer-land, France, Pakistan,
U.A.E., Saudi Arabia & India

Concurrent Event



Event Managed By



Supported by



Partner association



Organized By



Media Partner



For More Information, Please Contact

Radeecal Communications (Head Office, India) :- 402, 4th Floor, "Optionz" Complex,
Opp. Nest Hotel, Off C.G. Road, Navrangpura, Ahmedabad - 380009, Gujarat, India
Tel. +91 79 26401101/ 26401102/ 26401103 • M. +91 9173410748 • Email: mktg@radeecal.in

Please Contact For Stall Booking At Kenya Office :- Tel. : +254 722 171 765 • Email : kenya@agritecafrica.com

www.agritecafrica.com • www.radeecal.in



grows alstroemerias, statice, solidagos and limoniums blue. The flowers were bunched manually, but in March 2016, the quality buncher 2.0 Colombia edition of Havatec was installed. This is to deal with a decrease in availability of employees, and especially skilled employees, and an increase in labor costs. It is not only a tailored solution that will not just help instantly but also benefit in the future.

Colombian Growers Invest In Automation

It becomes harder for Colombian growers to find and keep workers as increasingly more jobs arise in the city. Moreover, the labour costs are increasing. So, in order to deal with this development, more and more growers are starting to automate parts of their production or post harvest processes. Bicco Farms is such a company. They are automating parts of their post harvest process and started to use a buncher machine this year.

Less and expensive labor

Colombia is strengthening its financial position. The Colombian economy is getting

better and better. Therefore increasingly well paid jobs are arising in the city which attract a lot of people from the 'country side. As a consequence less employees will be available to the Colombian growers. For this reason, increasingly more growers are looking for techniques that will improve the productivity of employees. Bicco Farms also decided to look for ways to do this and installed a bunching machine which will double the productivity of its post harvest employees.

Bicco Farms

Bicco Farms, located in the fertile savannah on the outskirts of Bogota, Colombia,

Customized orders

Havatec supplied Bicco Farms with their quality buncher 2.0 Colombia edition. This buncher is called the Colombia edition as it needs to fit in the 'flexible' Colombian post harvest process. "The regular quality buncher 2.0 is developed for mass bunching, so many of the same flowers are being bunched in the same quantities. In Colombia, however, they have a lot of customized orders, which means that they have to deal with different amount of stems per bunch. Moreover, many Colombian farmers often grow several flower varieties. All in all, this 'flexible' Colombian post harvest process resulted in a more flexible and easy to customize bunching machine: the quality buncher 2.0 Colombia edition," he concludes.

Be wary of downy mildew *By Joseph Maina*



They say that our crops are exposed to about 240 economically important pests and diseases and Downy mildew happens to be that disease affecting the many varieties of roses grown in Kenya today.

Downy Mildew is one of the major disease challenges to the floriculture industry whose control budget is about 20% of the total pesticide value. It occurs rapidly and the effects on the quality of roses is irreversible and the loss is irreparable.

What is downy mildew?

Downy mildew is a fungal disease that mainly causes destruction of leaves leading to massive defoliation. It's a disease of moist cloudy conditions which is active only in cool and damp conditions that causes severe and rapid defoliation - can defoliate an entire plant in 2 days. The causal organism being *Peronospora sparsa*, a fungus that is highly destructive and fast spreading in roses.

Downy mildew affects different parts of the plant such as the leaves, stems, peduncles, calyxes and petals hence affecting young growth



which may wilt. The leaf symptoms are Irregular-shaped, purple spots that form on the upper leaf surface while light grey brown spore masses form on the underside of the leaf. The brown spots look like injuries caused by a chemical spray. Older leaves infected first and then progressively younger leaves follow.

The fungus under unfavourable conditions, survives as mycelium or oospores in or on plant parts without showing disease signs but upon favourable conditions, mycelium growth resumes among the plant cells to produce oospores (fungal seeds) within 3 days. Oospores are spread by wind or water and germinate on leaf or other plant surface. Unlike powdery mildew spores, which are spread by the wind, downy mildew is spread by splashing water. Some farms carry over the disease from bud wood taken from infected stock during propagation.

How do you control downy mildew?

That's the question in some of if not all grower's mind and the many who are able to control it are able to identify the disease and it's stages,

looking for symptoms of early infection on older leaf tissue before chlorosis develops and identifying the symptoms before the disease reaches flowers, understanding the biology, the predisposing factors, monitoring the disease's progress which helps in predetermining the disease onset and coming up with an appropriate chemical intervention. Controlling the disease can be summarized into;

Field and Crop Hygiene: This involves maintaining greenhouse cleanliness, removing infected plant tissues & fallen plant debris well away from your production area since spores may survive and be viable on dried fallen leaves for as long as one month.

Cultural Practices which may include opening up the crop by pruning, improving greenhouse air ventilation by opening up vents especially at sunset when the greenhouse air is warm and moist while outside air is cool and drier. It is critical to keep relative humidity below 85% to decrease sporulation on infected plants and stop germination of spores on healthy plants. Humidity should not remain above 85% for more than 3 hours

Chemical Intervention: This is the last but not least method of controlling downy mildew. Crop protection products safeguard harvest yields, and thereby ensure that the flowers are of high quality. Many products give excellent control when used as preventive treatments rather than curative treatments. Growers should categorize the fungicides into Penetrant, Protectant, Post-infection, eradicant, Immune system enhancement etc. Another notable factor is the Spectrum of activity, Resistance concerns and IPM management coupled with crop safety.

There is need to position the chemical so as to interrupt the disease progress at the right point as well as the correct application which is critical.

BASF knows the threat of downy mildew and is constantly innovating new solutions that can stand the test of twenty first century grower demands and challenges. BASF has introduced **Orvego® 525SC** whose activity is superior in Downy mildew control.

Orvego® 525SC is a versatile element for your downy mildew spray program that maximizes the marketable yields of your crops – for all markets worldwide. It has dimethomorph and Initium™ that stops the flow of energy in the fungus like a valve stops the flow of fuel in a pipe as well as no cross resistance observed with other chemical classes. Initium is an innovation breakthrough by BASF and forms a very vital tool for resistance management as it's in a class of its own.

The parting shot is that the damage caused by Downy mildew is more or less dependent on the skill and experience of the grower who takes customer satisfaction a notch higher.

Joseph Maina is the BASF Ornamentals Manager - Kenya

INTRODUCTORY OFFER

10% OFF



NEW SQUARE FLOWER BUCKETS!

PROUDLY MADE **IN KENYA**

Introducing a new product, in keeping with better efficiency and output on the farm.

Features of the Flower Bucket include:

- Strong hand grip on two opposite sides
- Side stoppers to prevent tight stacking
- UV Stabilised thus withstanding the harmful effects of the sun
- Fill level graduation on the inside for accurate water levels
- Ideal design for flower transportation and storage
- Same footprint as round buckets
- Carries more stems than other buckets (approx. 15% more)
- Saves storage space lost using other buckets
- Available in various colours and specific colours for special orders
- Available with personalised names with a minimum order
- One year guarantee



Same footprint as round buckets, but 15% more carry space.



**SANPAC
Africa**
LIMITED

incorporating



SANPAC Africa limited

Tel: +254 (0)722 201 338, (0)733 201 338,
(0)756 201 338

Tel: +254 (0)20 211 2100/1/2/3

Email: sansales@sanpac.com or fpsmarketing@sanpac.com

P.O. Box 20496, Nairobi, 00200, Kenya

Off Mombasa Road, Next to Nation Media, Nairobi

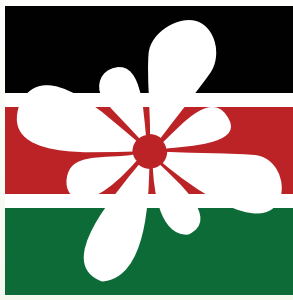

IFTTEX 2016

INTERNATIONAL FLOWER TRADE EXPO

WEDNESDAY JUNE 8 - FRIDAY JUNE 10

OSHWAL CENTER • NAIROBI • KENYA



Kenya's Flower Industry Expo



www.iftex.org

The Market Needs Some Good Orange Roses

The market needs some good orange colors”, says Alessandro Ghione of Nirp International. For this reason, this rose breeder invested years in enhancing their orange varieties and developing new ones. Lately, they introduced a new variety, called Tabasco and it is exclusively being grown by the Kenyan Fontana Group on 5ha. “The prices are encouraging and we are planning to plant another 3ha next year”, says Girish Appana, CEO at Fontana Group, a Kenyan flower farm that mainly exports to Europe.

Need for good orange color

According to Ghione, orange is a happy color which is purchased all year round, while other colors like yellow, red and white are more seasonal/periodical. Even though orange is a good color for year round production, the buyers are still looking for a longer lasting flower and more modern shapes. “We invested years in finding the right variety that fulfills these needs and we came up with the variety called Tabasco. This variety has a shelf life of 13 days



after transport and the buyers are loving this new orange variety. However, most of the compliments must be addressed to Appana, who has seen and believed in the great potential of Tabasco since the very beginning of the commercial selection process”, he says.

Exclusively grown by Fontana Group

The variety Tabasco is grown in Kenya by the Fontana Group under exclusive agreement. Appana: “At Fontana, we do strict selections from 2015 varieties. Only varieties that are not susceptible to botrytis, that have good vase life and after extensive testing are chosen. And the Tabasco was the chosen Orange among many varieties.” Nirp International was very pleased with this selection. “For us, as breeder, it is very important that a new variety is introduced on the market through excellent companies that will bring on the market high quality flowers. In this way the buyers will start to know and appreciate the new

variety. In particular, the first period is very important: positive first impressions are fundamental to start to generate interest in the novelty”, says Ghione.

Encouraging prices

According to Appana, the prices have been extremely encouraging. “It has proved a good decision to market the Tabasco”, says Appana. “Being a new variety and a standard Orange color it takes time for the market to pick the Tabasco as the preferred orange. However, the current prices are already comparable with the best orange varieties that are in the market. In the next few months, we hope the Tabasco becomes the preferred Orange. Then, we can get higher prices than the other oranges in the market.”

Increasing production

Fontana Group has 4 farms (collectively 110 hectares under greenhouse) in Kenya and are growing Tabasco in two of the high altitude farms; at 2600 meter and 2400 meter altitude. “In this way, the buyers will



always have access to Tabasco even if one of the farms have problems.” At those two farms, the Tabasco is planted over 5ha. “For a new variety and for the first planting this is a lot”, says Appana. They expect around 5,000,000 stems (around 60-70cm) of Tabasco from this area and next year, they are planning to plant another 3 ha. “Then we can supply the market with 8 million stems a year. And if the market wants more after that we will plant more Tabasco”, concludes Appana.

Royal De Ruiter East Africa Holds Successful Open Days Showcase

Royal De Ruiter East Africa welcomed African rose growers and other players in the floriculture industry to their first open house showcase this year. The two day event held on 9th and 10th March was an opportunity for Royal De Ruiter to showcase their current commercial varieties, new market introductions as well as code varieties.

“The open days were timely as we got to share with our partners our strategic plan moving forward especially after receiving our royal designation just before close of 2015,” said Edward Manning, MD Royal De Ruiter East Africa.

Notably present during the open days was one of Royal De Ruiter owner directors Henk de Groot who interacted with guests as they shared ideas and exchanged deals.



Some of the growers who visited on open day

Rose varieties bred at Royal De Ruiter are sold worldwide, supported by a network of agents and representatives who provide prospective buyers with carefully compiled information based on measurements carried out on our products at our various testing

facilities. Royal De Ruiter also has testing facilities in all of its production areas across the globe, an approach that has proved highly beneficial in realising the firm’s envisioned goals in respect of product differentiation.

Dutch Beauty! from Schreurs Grown at Bemack Farm Mt Kenya



Bemack Farm is located in the Mount Kenya region at an altitude of 2,500 meters above sea level. The 13ha farm managed by Mr. Rakesh Kutteih currently planted 5,000m² of orange Schreurs rose Dutch Beauty!. According to the farm’s packhouse manager, Hannington, this is a unique orange that has a striking and lovely color.

“What’s more unique is that at the vase, the rose opens up well without the color fading away making it a good choice for a arrangements,” he adds.

- Has a nice orange color
- Stem length 60 – 80cm
- Production 180 – 200 stems per M2 per year.
- Vase life 10 – 12 days
- Normal susceptibility to pests & diseases
- Head size 4 – 5cm
- Has very good presentation in the buckets & on the vase.

Olij & Jan Spek Roses for that Special Woman

Alpe d’huez

The Jan Spek variety, Alpe d’Huez is an almost pure white rose with a large bud and nicely shaped flower that boasts a unique symmetry. She is also a high producer with good stem-length. When the first bunches of the rose were introduced by Olij Holland, the prices were quite decent and immediately some comparisons started being drawn between Alpe d’huez and other leading roses in the white segment.



Top Yellow Kenyan Rose Varieties this Spring



It is said that Spring is the season of new beginnings. A time when earth rejuvenates and comes to life, bringing forth the best of the year. Just like Spring, yellow flowers hold the joy that comes with new beginnings. While most of the other roses such as reds and whites convey passion, love and romance; a yellow rose flower symbolize springtime, friendship, appreciation and devotion.

Kenya boasts an array of beautiful yellow roses that are appreciated across the world. They come in different shades, sizes and lengths, but the common factor amongst them is that they are all very attractive flowers.

Dummen Orange East Africa Inaugural 2016 Open Day

Dummen Orange East Africa (DOEA) was abuzz with activity as they hosted flower growers and other guests during their open days in Naivasha on 10th and 11th March. The entire showcase house was in a full beautiful bloom.

Dummen Orange top directors were also in town for the two day event and together with their East African counterparts shared their vision with the growers. Dummen Orange East Africa handles various cutflowers including standard and spray roses, indoor and outdoor carnations, chrysanthemums, statice, phlox, gypsophila, eryngium and solidago.

“We are currently testing several varieties of these flowers at flower farms in the region to gauge the market reaction which will then act as a guide to growers on how and what would be best to grow,” said Peter Mwangi GM Dummen Orange East Africa.

“By merging top breeders and other brands in the industry and blending traditional techniques with modern technologies,

Dummen Orange is able to produce superior flowers for the market,” adds Peter.

According to Steve Outram (Dummen Orange East Africa Sales Manager), their

“Initially, we mostly had big headed roses that were lower in production but now we have added into our assortment smaller headed roses that are



target for this year is to cover 70 hectares in the region. An effort he describes as ‘no mean feat’ but one that is achievable especially after last year’s acquisition of Terra Nigra.

high producers, says Steve. Dummen Orange adopted its present brand in 2015, which is a collection of several other excellent brands.

Van Den Berg Sues Kenya Revenue Authority

A flower company in Naivasha is contesting a demand for payment of Sh1.3 billion tax by Kenya revenue authority, saying the formula used threatens the industry. Van Den Berg Kenya Ltd claims the Kenya Revenue Authority used an incorrect formula to arrive at the tax figure for 2008-2013.

Through lawyer Tom Ojienda, the company said the taxman insists on demanding “unsustainable and unreasonable taxes” even after the company had worked out the tax due and submitted its returns. “KRA bases its claim on a general formula and not on actual sales. This threatens the flower industry,” said Prof Ojienda.

Van Den Berg Kenya grows roses in Kenya and sells them to a related

company, Van Den Berg BV in the Netherlands.

KRA had demanded Sh2.1 billion but revised this to Sh1.3 billion after a few concessions. Prof Ojienda also said the authority violated the transfer pricing rules, which require that once an objection is made, it is bound to respond within a specific timeframe.

He said the authority failed to respond within the legally specified timeframe and the objection was thus deemed to have been allowed. Further, Prof Ojienda said the authority purported to adjust the flower firm’s sales for the years 2008-2010 to an average price of 0.10 Euros per stem. The company is seeking a declaration that the amount demanded and the formula used to arrive at the tax amount is unlawful. The hearing continues on May 18.

Mums were the favorite on Int. Women’s Day

Royal FloraHolland has analysed how the sales went during the holidays of the English Mother’s Day and International Women’s Day.

This year the English Mother’s Day fell on March 6. The purchasing weeks were thus a bit earlier this year than last year when that Mother’s Day fell on March 15. We have ascertained that about 10% more sales of cut flowers were achieved in the English market in the two weeks preceding the English Mother’s Day. This is due mostly to more flowers being sold (about 8% more) at a 2% higher price. We noted more spray chrysanthemums and tulips being given to mothers this year than last year. Roses were less popular this year: 10% fewer roses traded via the Netherlands were bought as presents for English mothers.

In the run up to International Women’s Day (8 March 2016), we noted a rise in sales of cut flowers of almost 8%. In particular, more flowers were sold. We have to take into account that additional sales were generated by the overlap with the English Mother’s Day. As International Women’s Day is a popular holiday especially in Russia, Royal FloraHolland paid particular attention to Russia. In line with recent developments in Russia, the trade to Russia around International Women’s Day was evidently under considerable pressure (8% less turnover).

Over 20% fewer flowers were sold. In particular, tulips were less popular this year compared to last year: 35% fewer stems were traded. Roses were also less attractive in terms of both quantity and price. The winner turned out to be the spray chrysanthemum, of which 10% more flowers were sold at a 15% higher price.



Our Knowledge, Your Success.

Correction and Clarification:

Amiran’s Dipnoy 60-V2

In an article and Ad in the *Floriculture Magazine* (issue of November- December 2015), it was stated that Amiran’s Dipnoy 60-V2 is for the control and prevention of botrytis. We would like to correct and clarify that Dipnoy is for the prolonging of flower vase life in post harvest management, the product has no attributes on the control of botrytis.

Amiran understands that post harvest systems play a critical role in enhancing the competitiveness of cut flowers which by nature are highly perishable. The company’s goal is to help its farmers in delivering the produce to the final consumer as good as when harvested.

We apologize for any misleading information or inconvenience caused. Feel free to contact us for any further clarifications.

Yolande van den Boom new CEO MPS



Extensive experience in primary sector, management, sustainability and certification was decisive in process of engagement

Yolande van den Boom (52) succeeds CEO Theo de Groot, who will retire mid July. Van den Boom was born in Rotterdam and is highly involved in themes like CSR and sustainability. Besides this she has extensive knowledge of food security and certificates in that area.

Van den Boom has extensive experience in certification,

agriculture and sustainability. She has been involved intensely in setting up and securing various food safety certification schemes. Amongst other projects she has also been involved in co-development of schedules on behalf of Stichting Milieu Keur (SMK). Van den Boom's extensive experience in sustainable business is very worthwhile for MPS, whose major focus is on greenhouse horticulture. Van den Boom: "I am very happy to join MPS. With my background, my years of experience as a commercial quality and operations director, my knowledge of change management and innovation, as well as my passion for sustainability, I hope to be able to strengthen the leading market position of MPS. All the pieces of the puzzle fall into place for me."

Bayer Cropscience Names new Floriculture Crop Manager



He takes over this role from Anthony Songoro who has been promoted to head the marketing department.

Mr. Kipchumba joins the group with a wealth of experience in both crop protection and flowers. He began his career as a grower with Penta flowers limited where he rose to assistant manager position. He has also served in several other organizations including Syngenta East Africa where he successfully served as an area manager.

Bayer Crop Science, a leader in innovation and solutions for the flowers industry in East Africa, announced that Mr. Leonard Kipchumba Cherop has been appointed to the new Crop Manager in charge of Floriculture effective April 2016.

Bayer Cropscience is fortunate to have someone with his knowledge and experience and hopes he will go a long way in improving its service offer further to the industry.

Hortivation Cup 2016: Who Designs the Most Beautiful Sun Terrace?

hortivation Instigates New Competition for Goods Presentation

Joining-In is Worthwhile: Winner Receives Professional POS Coaching
hortivation by IPM ESSEN will take place for the first time at Messe Kalkar from June 13 to 15, 2016. The creative get-together will pick up trends which are foreign to the sector and will show how these can be used for the green sector in order to boost the sales of plants. As an important part of the comprehensive accompanying programme, the hortivation Cup will support the vision of the fair concept and is addressed to garden centres and specialised retailers. The new competition will not only present market-ready concepts for the point of sale but will also give the exhibitors and the visitors new stimuli in order to become actively involved in the innovation process in the green sector and to refine ideas.

"The Sun Terrace - Green Oasis in the City" will be the motto of the innovative competition for goods presentation. The Rhineland State Horticultural Association will be the organiser and the promoter and will be provided with its platform at hortivation. Garden centres and specialised retailers will be called upon to design a terrace covering an area of twelve square metres with goods from all their ranges. No limits will be set on creativity. It should be possible to adopt the presentations one to one for the point of sale. Furthermore, the terraces will serve the trade public as a source of inspiration for successful goods presentation. In addition to a knowledgeable jury, the visitors will be able to choose their favourite terraces during the period of the fair. The winner will be selected on the last day of the fair.

The Cup-winning team will be presented in the media and will receive a cash prize amounting to Euro 500 as well as a one-day in-house workshop. In this case, a coach will accompany the winner and will give helpful tips for successful goods presentation which will ensure a strong turnover. The terraces in the second and third places will win Euro 300 and Euro 200 respectively.

hortivation Cup Online

Anybody who is curious can already obtain advance information about the participants in the Cup on the hortivation website. The teams are introduced in portraits and interviews. The winner's success story as well as all the other results will be published in a comprehensive form after the fair. Therefore, all the participants will profit from the hortivation Cup beyond the period of the event, too.

Application Documents are Available for Downloading

Any specialised retail trade businesses which are organised in professional bodies will be entitled to participate with their decoration teams consisting of gardening or floristry specialists and trainees. The terraces will be set up in the period from 3 p.m. to 8 p.m. on Sunday, June 12, 2016 or from 8 a.m. to 11 a.m. on Monday, June 13, 2016. The detailed participation conditions as well as all the necessary application and registration documents can be retrieved from www.hortivation.de.

East African Packaging Industries Ltd are Making Magic

“East African Packaging Industries LTD. are making magic. In one word, they exist for the sake of simplicity. They focus their efforts into taking on all the worries over packaging from their customers, leaving them to concentrate on their core activities. Their contribution to the business mix is brief, crisp, penetrating, perceptible and a creative insight into the minds of consumers. Memorable ideas, images and stories, where less is more and understanding triumphs over information”, I concluded as Mr Nick Barnes took us through the interview. In his narration from one department to the other, one statement kept on recurring, no compromise to quality.

Leading a company alongside a team of people who have some of the best managerial skills, with the best technology in the region and company culture is what makes the effort worthwhile. This is why you must speak to the team despite my general overview”, says Nick, in a 30 minute interview with **Floriculture Editor, Masila Kanyingi.**

EAPI Ltd has been accredited ISO 9000 Quality standard among many other standards. The quality system involves the setting of performance improvement standards and targets throughout the operations of a company, and reviews the performance rating of the supplier by its customers.

It is a customer oriented company and aims at customer satisfaction above everything else. No idea would be too radical for the company and it manufactures a whole range of standard sized flower. “Our expansion for the last four years has been both markets driven and technical. Our concentration has been on the market outside Kenya as well as Kenya’s growing sectors, mainly floriculture and horticulture, says Nick.

*In EAPI you have a
packaging solution
provider who minds
your pocket.*

Back Ground

EAPI Ltd has been operating in Kenya since 1959, when a sack plant was opened in Mombasa. The corrugated container division was started in 1967 when EAPI took over Kenya Box.

EAPI Ltd is comprised of the sack division, located in Mombasa and the corrugated container division in Nairobi. In Nairobi operations are divided into two units, Administration under the Managing Director who also oversees the general running of the company and the Factory under the Operations Director.

EAPI Ltd. is the largest purchaser of paper in East Africa, and also the largest supplier of tea sacks, cement bags and corrugated packaging. The corrugated box division has a market share which fluctuates between 20% and 30%, depending on the season of the year. There is considerable over-capacity in the box market, and EAPI Ltd is capable of meeting sales requirements within 11 hours shift for the most part of the year.



EAST AFRICAN PACKAGING INDUSTRIES LIMITED

HEAD OFFICE NAIROBI
Kitui Road, off Kampala Road
PO Box 30146, Nairobi 00100,
Kenya. Tel: 3955000/3955600
Fax: 3955500/3955601/3955468
Web: www.eapi.co.ke
Email: sales@eapi.co.ke

MOMBASA OFFICE
Corner Voi St. and Shimanzi Road
PO Box 90442, Mombasa 80100, Kenya.
Tel: 2225157/2225158/2225527/6
Fax: 2227551
Web: www.eapi.co.ke Email:
sales@msaeapi.co.ke



Freshly packed,
Freshly delivered



YOUR PREFERRED PAPER PACKAGING SOLUTIONS PROVIDER

The Right Carton

makes a world of *Difference*. Whether you pack Tea for the export market or export Horticulture, you can rely on our high-quality packaging solutions to ensure that your produce gets to the market in the same state it left the factory-fresh.

East African Packaging Industries Ltd

Nairobi (cartons) Tel: +254 (0) 20 395 5600 fax +254 (0) 20 395 5601 email: sales@eapi.co.ke

Mombasa (paper sacks) Tel: +254 (0) 41 222 5157/8 fax: +254 (0) 41 222 7551

email: sales@msaeapi.co.ke Web www.eapi.co.ke



News Flash

EAPI Limited has come up with an innovative packaging solution for export market. The solution is meant to save exporter millions of shillings in freight. This new shipper is simply light, strong and cost effective. Light is the right way to go and EAPI is the natural supplier of choice to deliver this USP. At EAPI we guarantee value for money.

E.A.P.I
Better By Design



Sappi Containerboard

Sappi's Containerboard offering is a complete solution of premium quality products, that results in increased production efficiency and lower cost end-use products.

Sappi, celebrating its 80th anniversary this year, has been a loyal supplier to the paper packaging industry for many decades. Although evolving, Sappi's strategy and mission is still firmly based on products and processes focused on woodfibre, with packaging identified as a strategic market segment showing strong global growth potential. As a consequence, Sappi has made, and continues to make, significant investments in their manufacturing operations to produce world class products.

Sappi's paper packaging products, used in the manufacture of boxes and cartons, contributes to economic growth through the export of fruit and vegetables packaged in boxes. Sappi offers an extensive range of premium quality fibre-based packaging products, and their extensive supply chain network is set up to service customer needs throughout the country. Innovative products meet industry requirements, in line with market trends for paper combinations with lightweighting, strength and cost advantages, without compromising on performance. Sappi also considers carbon footprint benefits of reduced road, air and sea-freight costs for packaging.

"Our product innovation is driven by market demand," says Richard Wells, General Manager Commercial, Sappi Paper and Paper Packaging. Sappi manufactures a range of fluting and liner paper products for the agricultural markets for packaging fresh fruit and vegetables. Sappi also produces paper packaging products for frozen meats and fish, as well as the industrial market where heavy duty boxes are required for transporting and shipping automotive parts, domestic appliances, beverages and cans.

Key product benefits

Products, such as KraftPride®, UltraFlute® and UltraTest®, used in box combinations offer customers versatility in application. KraftPride is a 3-ply virgin linerboard available in grammages from 140 to 330g/m². UltraFlute, a semi-chemical fluting made from virgin NSSC fibre, is available in grammages from 125 to 180g/m². The superior burst and strength properties of these products, together with high humidity performance, ensure that products retain strength over longer periods of time in changing cyclic humidity conditions experienced throughout the supply chain. The benefit to customers is that these properties prevent boxes from collapsing. KraftPride provides a superior print surface for greater aesthetic appeal of graphics on end-use boxes. This enables brands to differentiate from those of their competitors. UltraTest has a 100% kraft appearance and can substitute recycled liners.

"Our products carry international ISO 9001 and ISO 14001 certifications. The woodfibre used in our process is a renewable resource that is FSC® (Forest Stewardship Council®) certified, biodegradable and recyclable. In addition, relevant products are certified safe for food contact through BfR (Bundesinstitut für Risikobewertung). Paper packaging is an ideal medium to protect products from farm to market," says Wells.

Sappi is proud to be associated with East African Packaging Industries Ltd, a world class carton manufacturing facility.



sappi
Inspired by life

Operations

Statistics available reveal that Kenya is losing millions in freight and post-harvest handling of flowers. “This makes our flowers less competitive in the market”, said Mr Heinz P. Meyer, the operations director. Mr. Heinz who was accompanied by Mr Robert Muchiri, the Technical Manager, confirmed that for the last one year, the company has invested a lot to provide solution for these losses in addition to ensuring that there is no compromise on quality as well as training growers on cool chain and carton handling.

Production

“Quality is the hallmark of EAPI Ltd’s operation. The driving concern therefore is the desire to give clients the best quality products and services. Naturally we become part of the client, working alongside their production and marketing team”, says Mr Heinz. “Customers are assured of top class services courtesy of high qualified customer sensitive staff, state of art technology, and a host of well-focussed, customer centred



**Mr Heinz P. Meyer,
The Operations Director.**

business strategies, he adds”.

According to Mr. Heinz, consumers have the authority over product innovation and

planning, production scheduling as well as the sales, distribution and servicing of the product. They point out every single thing that must be improved.

Technology and innovation are the backbone of most of our processes at EAPI. It is in this respect that the technical team remain a major contributor in any achievement. They actively participate in coming up with the operational procedures and are instrumental in evaluations. Being part of the action team, they also spearhead programs for minimising of waste and energy. Machine down times due to breakdown is minimal. “We manage to weather this storm through our qualified and experienced staff. Through innovation, we have remained on the front line in developing improved packaging for our customers.

Our brands, corrugated cartons and paper sacks form our strength as leaders in quality and service in the market”, says Mr Heinz.

The state –of-the-art machines and corrugators has resulted in a competitive edge as far as quality and bulk production is concerned. The corrugator is capable of producing very low grammage single wall boards to heavy duty double wall boards. Another benefit is its ability to do coating of the boards which helps in improving of water resistance. The conversion die-cutting machines have a capability of both flat bed and rotary die-cutting and



We are proud to be associated with
EAST AFRICAN PACKAGING INDUSTRIES LTD
as we celebrate your 50th Anniversary together

- ▶ Import & Export of Airfreight & Seafreight
- ▶ Bond and Treo management
- ▶ Customs Clearance
- ▶ Warehousing
- ▶ Transport Contractors
- ▶ Local & International Courier Services



Nairobi Office: 1st Flr. PANESAR CENTRE Mombasa Rd.
 Tel: +254 (20) 230 1551 Cell: +254 713 064 432

Mombasa Office:
 2nd Flr. EXPRESS HOUSE Cell: +254 725 960 603

info@jemi.co.ke
jemi.co.ke



JEMI COURIER
 Your world @finger tips



**Mr Robert Muchiri,
the Technical Manager**

can print up to four colours. Our folder Gluer is capable of printing up to full colours and together with stitchers meets all the regular slotted cartons (RSC) requirements of our customers.

Light weight box concept

“The future of boxes is in ensuring that our customers save on freight

and quality” says Mr Muchiri. Adding, “Innovation is the key to production as well as processing of knowledge”. Armed with this, the technical department has introduced a box that will save the customer millions of shillings paid in freight. The light weight concept is a complete reversal from the conventional heavy waste-based fluting board. The box which is lighter will fetch lower freight cost and save money for the grower. Though no backing statistics available research shows growers will save over 16% of their current freight cost.

Additionally, the light box drop lightly compared to the heavy box hence minimal impact compared to the heavy. This will translate to strength retention in the cool chain. The lighter box is done with a specialised fluting paper called semi-chemical fluting, which enables it to perform better in the cool chain and increase its residual strength. Box deterioration is also better hence impact of the packed product reduced.

Training: EAPI is also investing a lot on cool chain training and handling of boxes. The training is tailored to ensure growers product have none or minimal bruises before reaching the customer. In addition, it also ensures minimal friction if any during transport.

“A bruised product or neck bend product will be less competitive and fetch less than the market price”, says Robert Muchiri. Growers need to understand inserting of SFKs and handling of the flower box before and after packaging. In addition, the company trains on storage of the boxes.

Sales and Marketing

Packaging customers tend to leave the packaging hassles to experts in order to concentrate on their core activities. This is where EAPI comes in. As a packaging solutions provider; EAPI is not just offering a box. Their approach is different. “We challenge, innovate and inspire our customers. Our consultative approach is in finding alternative solutions to packaging needs. We add value by showing

how costs can be driven down while still retaining a competitive edge”, Says Ms Lucy Kinyanjui.

One of the challenges facing carton Manufactures is the movement of goods from the factory to the customer’s premises and or delivery points. This can be attributed to poor infrastructure and never-ending traffic jams.

Cartons are transported to customers in two ways. Some customers, mainly from the horticultural sector prefer collection on return after delivery of flowers at JKIA. EAPI has also out sourced a delivery services provider, who provides different truck sizes. “We use various activities to educate and benefit our customers. These include; participation in corporate social responsibility initiatives, taking part in some annual exhibitions notably IFTEX and the Naivasha Horticultural Fair”, Adds Lucy.

In today’s fast paced, high tech age, business must expand. EAPI Ltd has a bright future. Currently, they are serving most of the Comesa region with an eye to further expansion. The company is capable of handling any orders.

Challenges

“There are high costs of operations in Kenya which cannot be ignored such as electricity, finance, communications, infrastructure and custom duties when importing through the port, all these makes it clear why local packaging suppliers cannot produce and sale at internationally competitive rates”, Says Nick. Paper prices are such that they constitute over 60% of the cost of the manufactured carton, so there is little scope for great flexibility on selling prices.

Future Plans

EAPI, as a packaging solution provider is also partnering with growers to introduce glued boxes and phase out machine erected boxes. This will reduce injuries caused by staples while packaging or unpacking in addition to making the box firmer.

“On expansion, the focus is on the customer. They thrive on any challenge to develop solutions and improve the packaging of customers”, Says Nick.

Still in pipeline is the reduction of die cuts. “Looking at the standard box today, it has many different concepts on die cuts. While we all agree that the role of a die cut is ventilation, we disagree on the shape and the number of die cuts. Some growers prefer three while others go for two. The shapes range from rectangle, to circle or semi-circle. Standardizing them will cut more cost to the growers” says Mr Heinz.

In EAPI you have a packaging solution provider who minds your pocket.



The Kenya Flower Journey And The Beauty Of Partnerships

Reports that Kenya flowers are exported to 60 destinations across the world is not only heartwarming but serves to rubbers tamp the enviable position the industry occupies as a foreign exchange earner.

Only recently buyers at the World Floral Expo in Miami were wowed by the quality of Kenya flowers a pointer to better days ahead in the US. They expressed interest in learning more about our flowers and for the first time a delegation from US and Canada will be visiting the country's flower farms during the upcoming International Flower Show (IFTEX).

The show will bring buyers and importers for the fifth edition of IFTEX in Nairobi. The flower bonanza which has grown in numbers and stature should serve as a reminder of how much the industry players have invested in to capture the world attention.

It is worth noting that it is a huge honour as a country to be spearheading a break from the tradition. While about 65 per cent of exported flowers are sold through Dutch auctions, direct sales are starting to record impressive growth, reports indicate.

To attract an event of such global stature is no mean feat for the country, brings with it blessings and challenges in equal measure.

The increasing number of international buyers from Europe, especially from Holland, Germany, France and UK; Japan, Russia as well as other Eastern European, Middle East and non-European countries is surprising and indicates a strong growing interest from the buyers to get more directly involved with flower suppliers from Kenya.

The show has grown into a top Kenyan brand, strengthening the country's position as a leader in global markets, while enhancing the image of Nairobi as the home from where 40 per cent of the flowers sold in Europe originate.

But even as attention continues to be concentrated on increasing and diversifying markets, there is greater if not equal focus to quality and responsible production practices for continued market access and sustainability. And with new markets opening up fast demand will need to be matched with consistent and high production. And this means flower growers both small and large scale would require necessary assistance and infrastructure to up production.

And anyone keen on the flower industry knows that much as it is one of the country's biggest export earners falling under the larger horticultural sector, production challenges abound requiring the attention of everyone from the grower to government. Pests and diseases for example have been every grower's key concern. What has taken months to nurture and tend to may be spoilt in a matter of seconds by voracious and sap hungry pests. However there has been a resolve by pests and diseases control products in the floriculture industry in check. Elgon Kenya Limited for example has been active in the flower industry through partnerships with respected global brands to ensure it gives the farmers timely and high quality remedies on the farm.

This inspired by the need to provide cutting edge solutions to an industry that offers livelihoods to over 500,000 Kenyans. Through the National Farmers Awards that has been a classic example of the successes of public private partnership, Elgon Kenya in partnership with the Ministry of Agriculture, Livestock and Fisheries has sought to reward players in the sector who work tirelessly to keep the country fed while building the reputation and pride of the country in the global arena.

On behalf of Elgon Kenya, I wish the International Flower Trade Expo Kenya a happy fifth birthday. We look forward to an event that will keep recording towering success and helping Kenya becomes the world's largest producer and exporter of flowers; we have the resources, the capacity and the will power. Let's do this.



Partners of Floriculture



Our Knowledge, Your Success.



ELGON KENYA LIMITED

Organix Limited



PACKAGING MATERIALS LTD



Dow AgroSciences



THE HEART OF FRESHNESS



Environmentally intelligent farming



The Monarch Insurance

A friend for life.



Floriculture encourages the pursuit of joint activities in areas of mutual interest with national and international societies, companies and organizations. Agreements have been reached between Floriculture, leading growers and suppliers and trade associations. This unique partnership includes a complimentary copy for each member of the registered associations. Floriculture is proud to announce the cooperation with the above corporates.



FLOWER & VEGETABLE FARMS IN KENYA

FARM NAME	PRODUCT	LOCATION	CONTACT PERSON	TELEPHONE	E-MAIL
AAA- Flowers		Nakuru	Banerjee	0704788852	banerjee@aaagrowers.co.ke
AAA Growers	Vegetables/Flowers	Nairobi	Musa Sando	0787866022	sando@aaagrowers.co.ke
AAA-Chestnut		Narumoru	Kiai/Sando	0722944030	sando@aaagrowers.co.ke
AAA-Growers		Nakuru	Moses Sando	0787866022	sando@aaagrowers.co.ke
AAA-Hippo		Thika	Steve	0721778736	julius@aaagrowers.co.ke
AAA-Roses		Rumuruti	Julius Ruto	0720330039	turiagronomy@aaagrowers.co.ke
Acacia Farm-Sunripe		Naivasha	Antony	0711827785	naivasha@sunripe.co.ke
Africala		Limuru	Rob	0721-837968	sales@africala.com
African Blooms	Roses	Nakuru	Samir Chandorkar	0735384552	samir.chandorkar@xflora.net
Afriscan Kenya Ltd	Hypericum	Naivasha	Reuben Kanyi	0723920237	
AgriFlora Ltd	Flowers	Nakuru	Clement Kipngetchi		cngetich@sianroses.co.ke
Akina Farm	Roses	Nakuru	Arfhan	0722728441	arfhan@fontana.co.ke
Alani Gardens	Roses	Nakuru	Judith Zuurbier	0722 364 943	alani@alani-gardens.com
Altitude Flowers	Flowers	Nakuru	Dominic Koeh	0723684277	
Aquila Development Co	Roses	Naivasha	Prakash Shinde	0710791746	pm@aquilaflowers.com
Ayana Farm	Roses	Nakuru	Gideon Maina	0721178974	gideon@fontana.co.ke
Bamboo Farm-Sunripe		Nakuru	Reuben	0723920237	
Balaji	Roses	Olkalou	BalasahebIngawae	0735593016	balasaheb.ingawale4@gmail.com
Baraka Farm	Roses	Nakuru	Lucy	0720554106	lucy@barakaroses.com
Batian Flowers	Roses	Nanyuki	Dirk Looj	0720102237	dirk@batianflowers.com
Beautyline	Flowers	Naivasha	Peter Gathiaka	0722676925	peter@beautyli.com
Bigot Flowers	Flowers	Naivasha	Kakasaheb Jagtap	0722205271	jagtap.kt@bigotflowers.co.ke
Bila Shaka Flowers	Roses	Naivasha	Joost Zuurbier	0722204489	bilashaka.flowers@zuurbier.com
Bondent	Eryngiums	Nanyuki	Richard Fernandes	062-31023/6	bondent.production@karik.biz
Black Petals		Limuru	Nirzar Jundre	0722848560	nj@blackpetals.co.ke
Blissflora Ltd	Roses	Nakuru	Apachu Sachin	0789101060	appachu7@yahoo.com
Blue Sky		Naivasha	Mike	0720005294	info@blueskykenya.com
Blooming Dale Roses Kenya Ltd	Flowers	Nanyuki	Sunil	0718991182	info@bloomingdaleroses.com
Buds and Blooms		Nakuru	Shivaji	0720895911	shivaniket@yahoo.com
Carnation Plants	Roses	Athiriver	Ami R.	0733626941	amir@exoticfields.com
Carzan Kipipiri	Flowers	Naivasha	Nicholas	0721844367	kipipiri.production@carzankenya.com
Carzan Kipipiri	Flowers	Naivasha	Justus Metto	0722755396	gm@carzankenya.com
Carzan Rongai		Nakuru	Paul M.	0711838689	rongai.production@carzankenya.com
Charm Flowers	Flowers	Athiriver	Ashok Patel	020 352583	ashki@wananchi.com
Colour Crops	Hypericum	Nanyuki	Vincent	0721652231	colourcrops@tmu.com
Colour crops	Flowers	Nakuru	Maina	0722578684	bahati@colourcrops.com
Colour crops Naivasha	Flowers	Naivasha	Geoffrey Mwaura	0722200972	nva@colourcrops.com
Countrywide Connections		Nanyuki	Peterson Thuita	0724786004	bondet.production@kariki.biz
Delemere Pivot		Naivasha	Daniel Ondiek	0720395963	daniel.ondiek@vegpro-group.com
Desire Flowers	Flowers	Isinya	Rajat Chaohan	0724264653	rajatchaohan@hotmail.com
De ruiters	Breeder Roses	Naivasha	Fred Okinda	0722579204	Fred.okinda@deruiter.com
Double Dutch	Cuttings	Naivasha	James Opiyo	0723516172	Opiyojames160@gmail.com
Duro Farms (Rain Forest land)	Roses	Naivasha	Julius Kigamba	0723665509	jkigamba@fleurafrica.com
Elbur flora	Roses	Nakuru	Daniel Moge		
Enkasiti Thika	Flowers	Thika	Tambe	0734256798	enkasiti@gmail.com
Equator Roses	Flowers	Eldoret	Charles Mulemba	0721311279	cmulemba@sianroses.co.ke
Equinox	Flowers	Nanyuki	Tom Lawrence	0722312577 T	tom@equinoxflowers.com
Everflora Ltd.		Thika	-	0735873798	everflora@dmbgroup.com
Fairy Flowers	Flowers	Limuru	Sylvester	0753444237	sylvesterkahoro@yahoo.com
Fides Kenya Ltd	Cuttings	Embu	Francis Mwangi	068-30776	
Flamingo Holdings Ltd-Flamingo	Flowers	Naivasha	Peter Mwangi	0722204505	
Flamingo Holdings Ltd- Ibis	Flowers	Nanyuki	Purity Thigira	0722279176	
Flamingo Holdings Ltd-Kingfisher	Flowers	Naivasha	Charles Njuki	0724391288	
Flamingo Holdings Ltd- Kingfisher	Flowers	Naivasha	Jacob Wanyonyi	0722773560	
Flamingo Holdings Ltd- Ibis Farm	Vegetables	Nanyuki	Augustine Mwebia	0721447430	
Flamingo Holdings Ltd-Siraji Farm	Carnations, Roses	Nanyuki	John Magara/Peris	0729050116	
Finlays -Kericho	Flowers	Kericho	Elijah Getiro	0722873539	



FLOWER & VEGETABLE FARMS IN KENYA

FARM NAME	PRODUCT	LOCATION	CONTACT PERSON	TELEPHONE	E-MAIL
Finlays -Tarakwet	Flowers	Kericho	Japheth Langat	0722863527	japhet.langat@finlays.co.ke
Finlays Chemirel	Flowers	Kericho	Aggrey Simiyu	0722601639	aggrey.simiyu@finlays.co.ke
Finlays- Lemotit	Flowers	Kericho	Richard Siele	0721486313	richard.siele@finlays.co.ke
Flamingo flora	Roses	Njoro	Sam Nyoro	0721993857	s.ivor@flamingoflora.co.ke
Flora ola	Roses, Hypericum	Solai-Nakuru	Wafula	08382972	floraolaltd@gmail.com
Flora Delight		Kiambu/ Limuru	Marco	0710802065	marcovansandijk@yahoo.com
Florensis Ltd	Cuttings	Naivasha	Anne Marie		annemarie@florensis.co.ke
Florenza	Roses	Nakuru	Yogesh	0715817369	
Fontana Ltd-Salgaa		Nakuru	Kimani	0733605219	production@fontana.co.ke
Fontana Ltd		Nakuru	Girrish Appana	0726089555	production@fontana.co.ke
Fox Ton Agri		Naivasha	Jim Fox	0722204816	jim@foxtonagri.com
Fpeak		Thika	Mutiso/Titus	0711214396	anthonymutiso@gmail.com
Frigoken K Ltd	Vegetables	Nairobi	Nicholas Kahiga	0722797547	nicholas.kahiga@frigoken.com
Gatoka Roses	Roses	Thika	Chris	0723408471	gatoka@swiftkenya.com
Gladioli Ltd		Naivasha	Pieriguichi / Claudia	0722206939	torres.palau@yahoo.com
Golden Tulip	Roses	Nakuru	Ravi	0723159076	ravi@bth.co.ke
Golden Tulip (Laurel Inter.)	Roses	Nakuru	Ashok	0738359459	ashok@btl.co.ke
Gorge Farm		Naivasha	Patrick Mulumu	0722498267	pmulumu@vegpro-group.com
Groove	Flowers	Naivasha	John Ngoni	0724448601	grovekenya@gmail.com
Hamwe	Hypericum	Naivasha	Peter Kamwara	0721758644	hamwe.fm@kariki.biz
Hamwe- Molo	Fowers	Nakuru	Joseph Juma	0725643942	production.fm@kudenga.co.ke
Harvest / Manjo Plants	Roses	Naivasha	Phanuel Ochungu	0722506026	phanuel.ochunga@gmail.com
Harvest Ltd	Roses	Athiriver	Mr. Farai Madziva	0722-849329	farai@harvestflowers.com
Highland plantations	Cuttings & Herbs	Olkalou	Amos Mwaura	0726726392	production@highlandplants.co.ke
Imani Flowers	Flowers	Nakuru	Moses	0722977214	
Indu Farm		Naivasha	Wesley Koech	0715546908	
Indu -Olerai Farm		Nakuru	Everline Debonga	0723383160	everlyne.adhiambo@indu-farm.com
Interplant Roses	Roses	Naivasha	Gavin Mouritzen	0733220333	info@interplantea.co.ke
Isinya	Flowers	Isinya	Pradeep	0736586059	pm@isinyaroses.com
Jatflora		Naivasha	James Oketch	0724418541	jatflora@gmail.com
Jesse AGA		Mweiga	Thuranira	0754444630	davidt@eaga.co.ke
Karen Roses	Flowers	Nairobi	Peter Mutinda	0723353414	pmutinda@karenroses.com
Kariki Ltd.		Thika	Samwel Kamau	0723721748	production@kariki.co.ke
Karuturi	Flowers	Naivasha	Rob		rob.paul@twigaroses.co.ke
Twiga Flowers	Flowers	Naivasha	pius Kimani	0721747623	pius.kimani@gmail.com
Kenflora Limited		Kiambu/ Limuru	Abdul Aleem	0722311468	info@kenflora.com
Kentalya		Naivasha	Linnet	0733549773	lynette@kentalya.com
Kenya Cuttings	Flowers	Ruiru	James Ouma	0725217284	john.odhiambo@syngenta.com
Kenya Cuttings	Flowers	Thika	Kavosi Philip	0721225540	philip.munyoki@syngenta.com
Kenya Pollen Flowers	Flowers	Thika	Joseph Ayieko	0733552500	joseph.ayieko@syngenta.com
KHE		Nanyuki	Elijah Mutiso	0722254757	mutiso@khekenya.com
Kisima Farm	Roses	Timau	Martin Dyer	0722593911	martin@kisima.co.ke
Kongoni River Farm-Gorge Farm	Roses	Naivasha	Anand Patil	0728608785	anand.patil@vegpro-group.com
Korongo Farm		Naivasha	Macharia	0721387216	
Kreative	Roses	Naivasha	Bas Smit	0722 200643	info@kordesroses.com
Lamorna Ltd	Roses	Naivasha	Mureithi	0722238474	admin@lamornaflores.com
Lathyflora		Limuru	Mbauni John	0721798710	mbaunij@yahoo.com
Lauren International	Flowers	Thika	Chris Ogutu/Carlos	0722783598	laurenflowers@accesskenya.co.ke
Lex International	Roses	Naivasha	Steve Outram	0733 609863	steve@lex-ea.com
Liki River	Flowers	Nanyuki	Madhav Lengare	0722202342	madhav@vegpro-group.com
Liki River	Flowers	Nanyuki	Nitin	0700000342	nitin.golam@vegpro-group.com
Livewire	Hypericum	Naivasha	Esau Onyango	0728606878	management@livewire.co.ke
Lobelia Ltd/ Sunland	Roses	Timau	Peter Viljoen	0721632877	info@lobelia.co.ke
Lolomarik	Roses	Nanyuki	Topper Murry	0715 727991	topper@lolomarik.com
Loldia Farm		Naivasha	Gary/Rotich	0720651363	
Longonot Horticulture		Naivasha	Chandu	0724639898	chandrakant.bache@vegpro-group.com
Longonot Horticulture		Naivasha	Patrick Mulumu	0722498267	patrick.mulumu@vegpro-group.com
Maasai Flowers	Flowers	Isinya	Andrew Tubei	0722728364	atubei@sianroses.co.ke



FLOWER & VEGETABLE FARMS IN KENYA

FARM NAME	PRODUCT	LOCATION	CONTACT PERSON	TELEPHONE	E-MAIL
Magana	Roses	Nairobi	Lukas	0788695625	farmmanager@maganaflovers.com
Mahee	Roses	Nakuru	Senthil Bharathi	0789777145	maheefm@eaga.co.ke
Mahee Wilham	Vegetables	Nakuru	Missire	0754444629	maheevgef@eaga.co.ke
Maji Mazuri Roses	Flowers	Eldoret	Wilfred Munyao	0725848912	wmunyao@majimazuri.co.ke
Maridadi Flowers	Flowers	Naivasha	Jack Kneppers	0733333289	jack@maridadiflowers.com
Maua Agritech	Flowers	Isinya	Madan Chavan	0738669799	production@mauaagritech.com
Mauflora	Roses	Nakuru	Mahesh	0787765684	mahesh@mauflora.co.ke
Milmet/Tindress Farms	Flowers	Nakuru	Pravin		pravinyadav.29@gmail.com
Molo River Roses	Flowers	Nakuru	A. Wambua	0724256592	awambua@moloriverroses.co.ke
Mwanzi Farm	Roses	Rumuruti	Peter Wekesa	0723027208	
Mt Elgon Flowers	Roses	Eldoret	Bob Anderson	0735329395,	bob@mtelgon.com
Mweiga Blooms	Flowers	Nanyuki	Stewart/ Mburu	0721674355	mweigablooms@wananchi.com
New holland - Laurel Investment	Roses	Nakuru	Ashok	0738359459	
Nini Farms	Roses	Naivasha	Menjo / Philip	0720611623	production@nini ltd.com
Nirp East Africa	Roses	Naivasha	Danielle Spinks	0702685581	danielles@nirpinternational.com
OI Njorowa	Roses	Naivasha	Charles Kinyanjui	0723986467	mbegufarm@iconnect.co.ke
Olij Kenya Ltd	Roses	Naivasha	Sally Nicholas	0737888028	v.bhosale@olijkenya.com
Oserian	Flowers	Naivasha	Musyoka Stephen	0722888377	stephen.musyoka@oserial.com
Panda Flowers	Roses	Naivasha	Chakra	0786143515	chakra@pandaflowers.co.ke
Panocol International	Roses	Eldoret	Mr. Paul Wekesa	0722748298	paul.wekesa@panocal.co.ke
Penta	Flowers	Thika	Tom Ochieng	0723904006	tom@wananchi.com
United Selections	Roses	Nakuru	Benard Ndungu	0721630887	
Pj Dave	Flowers	Isinya	Simiyu	0723500049	pjdavetimau@pidaveepz.com
Pj Flora	Flowers	Isinya	Palani Muthiah	0752607651	muthiah.palani1971@gmail.com
Pj Thande Farm		Kiambu/Limuru	Elizabeth Thande	0722380358	elizabeth@wetfarm.co.ke
Plantation Plants	Cuttings	Naivasha	William Momanyi	050 20 20282	pplants@kenyaweb.com
Porini Ltd	Flowers	Nakuru	Pitambar Ghahre	0726774955	porini@isinyaroses.com
PP Flora	Roses	Nakuru	Robert /Prakash	0718045200	ppflora2010@gmail.com
Primarosa	Flowers	Athi RiVer	Dilip Barge	0731000404	dilip@primarosaflovers.com
Primarosa	Roses	Nakuru	Kadam	0721274413	kadam@zuri.co.ke
Racemes Ltd		Naivasha	Bonny	0721938109	bonny@kenyaweb.com
Ravine Roses Flowers	Flowers	Nakuru	Peter Kamuren	0722205657	pkamuren@karenroses.com
Redland Roses		Thika	Aldric Spindler	0733603572	aldric@redlandsroses.co.ke
Redwing Flowers	Flowers	Nakuru	Simon Sayer	0722227278	sayer@redwingltd.co.ke
Rift Valley Flowers Ltd	Flowers	Naivasha	Peterson Muchuri	0721216026	fm@riftvalleyroses.co.ke
Rimiflora Ltd		NaivaSha	Richard / Stephen	0722357678	richard@rimiflora.com
Riverdale Blooms Ltd		Thika	Antony Mutugi	0202095901	rdale@swiftkenya.com
Roseto	Roses	Nakuru			gm.roseto@megaspingroup.com
Rozzika Gardens –Kamuta Farm		Naivasha	Mbuthia	0721849045	jwachiram@yahoo.com
Savannah international	Geranium	Naivasha	Ignatius lukulu	0728424902	i.lukulu@savanna-international.com
Selecta Kenya		Thika	Alnoch Ludwig	0738572456	l.allnoch@selectakenya.com
Soljanmi	Fowers	Njoro	Kirani Nangare	0787787544	kiran.nangare@xflora.net
Schreus	Roses	Naivasha	Pradeep		
Shades Horticulture	Flowers	Isinya	Mishra	0722972018	info@shadeshorticulture.com
Shalimar Flowers	Flowers	Naivasha	Anabarasan	0733604890	anbarasan@eaga.co.ke
Sierra flowers Ltd	Flowers	Nakuru	Sherif	0787243952	farm.sierra@megaspingroup.com
Simbi Roses		Thika	Karue	067 44292	simbi@sansora.co.ke
Sirgoek Flowers	Flowers	Eldoret	Andrew Keitany	0715 946429	sirgeok@africaonline.co.ke
Solai Milmet/Tindress	Flowers	Nakuru	Ravindra	0788761964	tindressmilmet@gmail.com
Star Flowers Flowers	Flowers	Naivasha	Dinkar	0789487429	dinkar@vegpro-group.com
Subati Flowers	Flowers	Nakuru	Naren Patel	0712 584124	naren@subatiflowers.com
Subati Flowers	Flowers	Naivasha	Naren Patel	0712 584124	naren@subatiflowers.com
Suera Flowers Ltd	Flowers	Nakuru	George Buuri	0724622638	gbuuri@suerafarm.sgc.co.ke
Sun buds	Hypericum	Naivasha	Reuben Kanyi	0723920237	kanyireuben@gmail.com
	Gypsophilla, Army				
Sunland Timau Flair	Roses	Timau	Peter Viljoen	0723383736	info@lobelia.co.ke
Stockman rozen	Roses	Naivasha	Julius muchiri	0708220408	julius@srk.co.ke
Tambuzi	Roses	Nanyuki	Paul Salim	0722 716158	paul.salim@tambuzi.co.ke



FLOWER & VEGETABLE FARMS IN KENYA

FARM NAME	PRODUCT	LOCATION	CONTACT PERSON	TELEPHONE	E-MAIL
Terra nigra	Breeder--1ha	Naivasha	Peter van der meer		petervandermeer@terranigra.com
Timaflo Ltd	Flowers	Nanyuki	Simon van de Berg	0724443262	info@timaflo.com
Transebel		Thika	David Muchiri	0724646810	davidmuchiri@transebel.co.ke
Tropiflora		Kiambu/Limuru	Niraj		tropiflora@africaonline.co.ke
Tulaga	Roses	Naivasha	Steve Alai	0722659280	tulagaflower@africaonline.co.ke
Tk Farm		Nakuru	Gichuki	0721499043	davidgichuki20@yahoo.com
Uhuru Flowers	Flowers	Nanyuki	Ivan Freeman	0713889574	ivan@uhuruflowers.co.ke]
V.D.Berg Roses	Flowers	Naivasha	Johan Remeeus	0721868312	
Valentine Ltd		Kiambu/Limuru	Maera Simon	0721583501	simon.maera@valentinegrowers.com
Van Kleef Ltd	Roses	Nakuru	Judith Zuurbier	0722 364 943	judith@vankleef.nl
Vegpro K Ltd Vegetables		Nanyuki	John Kirunja	0729555499	john.kirunja@vegpro-group.com
Vegpro K Ltd	Vegetables	Nairobi	Judy Matheka	0721245173	jmatheka@vegpro-group.com
Vegpro K Ltd	Vegetables	Nanyuki	John Nduru	0722202341	jnduru@vegpro-group.com
WAC International	Breeder	Naivasha	Richard Mc Gonnell	0722810968	richard@wac-international.com
Waridi Ltd		Athiriver	P. D.Kadlag	0724-407889	kadlag@waridifarm.com
Wildfire	Flowers	Naivasha	Boniface Kiama	0722780811	roses@wildfire-flowers.com
Wilmer	Summer Flowers	Thika	Wilfred M.Kamami	0733714191	kamami@wilmar.co.ke
Winchester Farm	Flowers	Nairobi	Raphael Mulinge	0725848909	rmulinge@sianroses.co.ke
Windsor		Thika	Vikash	073705070	vikash@windsor-flowers.com
Xpression Flora		Nakuru	Mangesh Rosam	0720519397	mangesh.rasam@xflora.net
Zena	Roses	Thika	Arun Mishra	020 2328970	sales@zenaroses.co.ke
Zena Asai Farm	Roses	Eldoret	Laban Koima	0722554119	koima@zenaroses.co.ke
Zena Roses - Sosiani	Roses	Eldoret	Sylvester Saruni	0722635325	saruni@zenaroses.co.ke

FLOWER FARMS IN UGANDA

TYPE	FARM NAME	CONTACT PERSON	LOCATION	PHONE NUMBERS	E-MAIL
Roses	Rosebud	Ravi Kumar	Wakiso	0752 711 781	ravi.kumar@rosebudlimited.com
Roses	Maiye Estates	Premal	Kikwenda wakiso		premal@maiye.co.ug
Roses	Jambo flowers	Patrick Mutoro	Nakawuka Sisia Wakiso	(254) 726549791	pmutoro80@yahoo.co.uk
Roses	Pearl Flowers	Raghibir Sandhu	Ntemagalo Wakiso	0772 72 55 67	pearl@utlonline.co.ug
Roses	Aurum flowers	Kunal Lodhia Shiva	Bulega, Katabi Wakiso	0752 733 578	kunal@ucil.biz
Roses	Eruma roses	Kazibwe Lawrence	Mukono	0776 049987	kazibwe@erumaroses.com
Roses	Uga rose	Grace Mugisha	Katabi Wakiso	0772 452 425	ugarose@infocom.co.ug
Roses	Kajjansi	K.K rai	Kitende Wakiso	0752 722 128	kkrai@kajjansi-roses.com
Roses	Uganda Hortech	M.D hedge	Lugazi Mukono	0703 666 301	mdhedge@mehtagroup.com
Chrysanthemums	Fiduga	Jacques Schrier	Kiringente , Mpingi	0772 765 555	j.scherier@fiduga.com
Chrysanthemums	Royal Van Zanten	Jabber Abdul	Namaiba Mukono	0759 330 350	j.Abdul@royalvanzanten.com
Impatiens, poinsetia	Wagagai	Olav Boenders	Iwaka Bufulu Wakiso	0712 727377	olav@wagagai.com
Chrysanthemums	xclusive cuttings	Peter Benders	Gayaza- Zirowe rd	0757 777 700	pbenders@xclusiveuganda.com

FLOWER FARMS IN TANZANIA

TYPE	FARM NAME	CONTACT PERSON	LOCATION	PHONE NUMBERS	E-MAIL
Roses	Kili flora	Jerome Bruins	Arusha	255 27-25536 33	jbruins@habari.co.tz
Roses	Mt. Meru	Tretter	Arusha	255 27 2553385	office@mtmount-meru-flowers.com
Roses	Tengeru Flowers	Tretter	Arusha	255 27 255 3834	teflo@africaonline.co.tz
Roses	Hortanzia	Mr Micheal Owen	Arusha	255 784 200 827	hortanziagm@cybernet.co.tz
Hypericum	Kilimanjaro flair	Greg Emmanuel	Arusha	255 784 392 716	greg@kilimanjaroflair.com
Crysenthemums	Multi flower Ltd	Tjerk Scheltema	Arusha	255 27 250 1990	tjerk@arushacutting.com
Crysenthemums	Fides	Greg Emmanuel	Arusha	255 27 255 3148	fides@habari.co.tz
Crysenthemums	Dekker Bruins	Lucas Gerit	Arusha	255 27 255 3138	info@tfl.co.tz
Crysenthemums	Arusha cuttings	Tjerk Scheltema	Arusha	255 27 250 1990	tjerk@arushacutting.com



FLOWER FARMS IN ETHIOPIA

TYPE	FARM NAME	CONTACT PERSON	LOCATION	PHONE NUMBERS	E-MAIL
Roses	Linsen flowers	Peter Linsen	Holeta		Elinsenroset@ethionet.et
Roses	Hanjia	Holeta	0922 750602	Peter.Pardoen@karuturi.com	
Roses	Alliance flowers	Navale	Holeta		navele@nehainternational.com
Roses	Ethio dream Rishi	Holeta	Ethiopia	011 23 72335	holeta@jittuhorticulture.com
Roses	Holeta Roses Navale	Holeta	Ethiopia		navale@nehainternational.com
Roses	Supra Flowers	Kaka Shinde	Holeta	0911 353187	kakashind@rediffmail.com
Roses	Agriflora	M. Asokan	Holeta	0922 397760	flowers@ethionet.et
Roses	Ethio- Agricerft	Alazar	Holeta	0910 922 312	alazar@yahoo.com
Roses	Addisfloracom P.L.C	Kitema Mihret	Holeta	0912 264190	tasfaw@addisflora.com
Roses	Enyi- Ethio	Teshale	Sebata	0911 464629	enyi@ethionet.et
Roses	Lafto Roses	Andrew Wanjala	Sebata	0922 116 184	irrigation@laftorose.com
Roses	Eden Roses	Vibhav Agarwal	Sebata	0930 011228	vaibhavaggarwal1@hotmail.com
Roses	Ethio-passion	-	Sebata	0911 511 711	roshanmuthappa811@gmail.com
Roses	Golden Rose	Mr. Sunil	Sebata		
Roses	E.T Highlands		Sebata	0 911 50 21 47	bnf2etf@ethionet.et
Roses	Sharon Flowers		Sebata		saronfarm@ethionet.et
Roses	Selam Flowers	Etsegenet Shitaye	Sebata	0913 198440	etstgshita@yahoo.com
Roses	Joy Tech	mulugeta Meles	Debra Zyeit	0911 302804	mulugeta@joytechplc.com
Roses	Dugda floriculture	sayalfe Adane	Debra Zyeit	0911 50 48 93	general@dugdaflora.com.et
Roses	Minaye flowers	Eyob Kabebe	Debra Zyeit	011-3728667/8/9	minayefarm@ethionet.et
Roses	Bukito Flowers	Anteneh Tesfaye	Debra Zyeit	0911 615571	
Roses	oilij	Bas Van der lee	Debra Zyeit	0911 507 307	b.vanderlee@oilijethiopia.com
Roses	Yassin Flowers	Tesfaye Gidissa	Debra zyeit	0911 89 78 56	kemevision@yahoo.com
Roses	Z. K Flowers	Abebe Mamo	Debra zyeit	0911 52 65 29	abemic/2006@yahoo.com
Roses	Friendship flowers	Edwin	Debra zyeit	(251)91 130 49 67	friendship.flowers@yahoo.com
oses	Evergreen farm	Hiwot	Debra zyeit	0912 18 5065	Hiwot.Ayaneh@yahoo.com
Roses	Rainbow colours	Tadessa Kelbessa	Debra zyeit	0911 389 729	rainfarm@yahoo.com
Roses	Sher	Ramesh Patil	Ziway	0912 131940	rnpatilpune@yahoo.com
Roses	Braam farm	Ben Braam	Ziway	0920 7462 70	braam.roses@hotmail.com
Roses	Sher- Koka farm	Alemitu Biru	Ziway	0912 09 78 24	
Roses	Ziway Roses	Ermiyas Solomon	Ziway	0921 094373	ermiasziwayroses@yahoo.com
Roses	Herbug	Hubb	Ziway		hubb@herburgroses.nil
Roses	AQ	Wim	Ziway		wimjr@aqroses.com
Hypericum	Margin par	Hayo Hamster	Holeta	251 911 505 845	marginpar@ethionet.et
Gypsophila	Tal Flowers	Mr. Uri	Sebata		uridago@walla.co.il
Hydragiums	Ewf Flowers	Humphrey	Sebata	0920 35 1931	production-manager@Ewf-flowers.com
pelargoniums	Red fox	Michel Zevenbergen	Ziway	0911 49 00 23	m.zevenberge@ethiopia.redfox.de
Hypericum	Abssinia flowers	Sendafa			ggh_link@ethionet.et
Geraniums	Ethiopia cuttings	Scott Morahan	Koka		scott.moharan@syngenta.com
Budding plants	Florensis Ethiopia	Netsanet Tadasse	Koka		flrensis@ethionet.et
Crysanthemums	Maranque	Mark Drissen	Merjetu	(251) 22 1190750,	md@maranqueplants.com
Freesia & Statice	Freesia Ethiopia	Ronald Vijvrborg	Sebata	(251) 115 156259,	freesia@ethionet.et
Hypericum	Yelcona	Andreas	Sebata	0921 146 930	Andreasndieolens@hotmail.com

Closer 240SC Discussed in the Village Bunge

On arrival, I was met by Doctor Itila (Hitler) the village master. By look, Dr. (Debtor) Itila, a graduate of M P C (mad people's combination) but a victim of university expulsion before his PHD (Permanent Head Damage) from UON (university of nowhere) had been drinking for long. He stood with his trade mark; a cigar on his right side of the mouth and shouted, Ovisa..... (Officer). He then led me to one of the cubicles which was occupied by who is who from the village. Every one yelled giving me a wivaa as I crossed to the elite area. I promised to join them later.

Kyalii (Charles), the first graduate of horticulture in the village and a General Manager in one of the leading flower exporters in the region was busy irrigating his throat surrounded by some young men who I later learnt they were middle level managers in different flower farms. They call him Chairman for he helped them to their current working stations after their graduation. Ovisaa..... he shouted as he stood to usher me. He went on to introduce me to the young men who claimed they knew me but I could not remember seen them. As I sat down, Sikolasitika (Scholastica) came in escorted by Itila carrying a Madiaba Krest. "We know what you take bwana, do not waste your saliva talking to this village women", Itila said as she opened it for me.

Mealy Bugs Attack

After greetings, Juma whom I later learnt was a production manager with one of the flower farms said, Chairman, the officer, all dignitaries, in attendance allow me to share a serious problem I have noted in the farm. He cleared his throat. "Two days ago, I noticed dropping of leaves, minimal plant growth particularly new shoots and yellow spots and wilting. This has greatly impacted my production".

"That sounds like a case of mealybugs" said Endelea (Andrew) a production manager with another flower exporter. Chairman seated next to me pinched me and whispered, "I always sit quietly and I listen to the young turks debate". "True and mealy bugs are notorious notifiable pests, take care", said Mutiso, a consulting agronomist.

Mr. Mutiso whom they popularly called Professor sipped a mouthful of tusker lager and cleared his throat once more. He continued, "Mealybugs damage plants with their toxic saliva, causing leaves to drop, inhibiting plant growth particularly of new shoots and creating yellow spots. Mealybugs can be difficult to treat because they hide in crevices where stems meet leaves and can reach damaging population levels rather quickly.

They are normally located on the underside of plant leaves and stems, and populate many outdoor plants. Mealybugs will heavily infest almost any plants in greenhouses, homes or businesses. They feed by forcing their needle-like piercing mouthparts into the plant and use a sucking action to remove the plant juices. Mealybugs attract ants by excreting honeydew, a sticky, sweet substance that the ants feed on. Plants infested with mealybugs usually have leaves that turn yellow and wilt, and if the infestation is not eliminated, the plant may eventually die. In Roses new shoots are prevented from growing and this greatly impacts production.

(Interruption from colleagues clapping and foot thumping shouting prof... prof... prof....). I beg to continue, he said. Once the crawler selects a feeding site, it inserts its mouthpart (called a stylet) and begins feeding on plant sap. While eating, a sticky waste substance is excreted by the insect (commonly called honeydew). This liquid adheres to leaves and provides a medium for sooty mould to colonize and grow. Sooty mould is black and eventually covers leaves and stems. This mould inhibits infected portions of the plant from photosynthesizing and causes aesthetic damage. In addition to the sooty mould, plant damage is caused by the mealybugs sucking plant sap and the pests' toxic saliva, both resulting in distorted plant growth and premature leaf drop as well as no emerging of new shoots. Plant leaves also develop yellow chlorotic spots.

Closer 240 SC

Avakuku (Habakuk) who was quiet all through and looked slightly older than the rest said, "but I thought this should no longer be a problem

anymore". "Why?" Choral question from the rest. "Did you guys attend the Closer 240 SC launch", he asked. Closer 240SC is a unique technology from Dow Agrosiences, the industry experts. It has effective residual control on mealy bugs, aphids and whiteflies.

Oh yes, prof took over, I did attend. Closer 240SC is powered by Isoclast™ active (sulfoxaflor), discovered by and proprietary to Dow AgroSciences, currently is the sole member of a new chemical class of insecticides, the sulfoximines in the chemical class 4C. Isoclast has been developed globally for use in major crop groups, including Roses, Carnations etc. Isoclast controls economically important and difficult-to control sap-feeding insect pests including most species of aphids, mealybugs and whiteflies.

Why use Closer 240SC

Closer 240SC is effective at low use rates, has excellent knockdown and residual control and excellent translaminar and systemic activity.

In addition, it is effective against insect pest populations resistant to other insecticides, and a valuable rotation partner with other chemistries i.e. Neonicotinoids. Closer 240SC has minimal impact on beneficial insects, including bees and natural enemies, when applicators follow label directions for use.

Closing Remarks

For the first time, the Chairman spoke; I did the trials and have personally used it. It is an excellent product against mealybugs. It is what the industry needs now. I request each one of you to use.

By this time the football match was over and those who had been taking Muatine were speaking in tongues. The sergeants at arms were very busy throwing them out. On our table, members showed they could not pass an alcoblow test. The Chairman called off the session of the day with an appeal to Mr. Juma, Use Closer 240SC before mealybugs close your greenhouse.

Members of my profession, this is what I miss as I try to depreciate my fingers in the city.

A BRIGHT SOLUTION IS ABOUT TO UNFOLD
Don't miss this ...

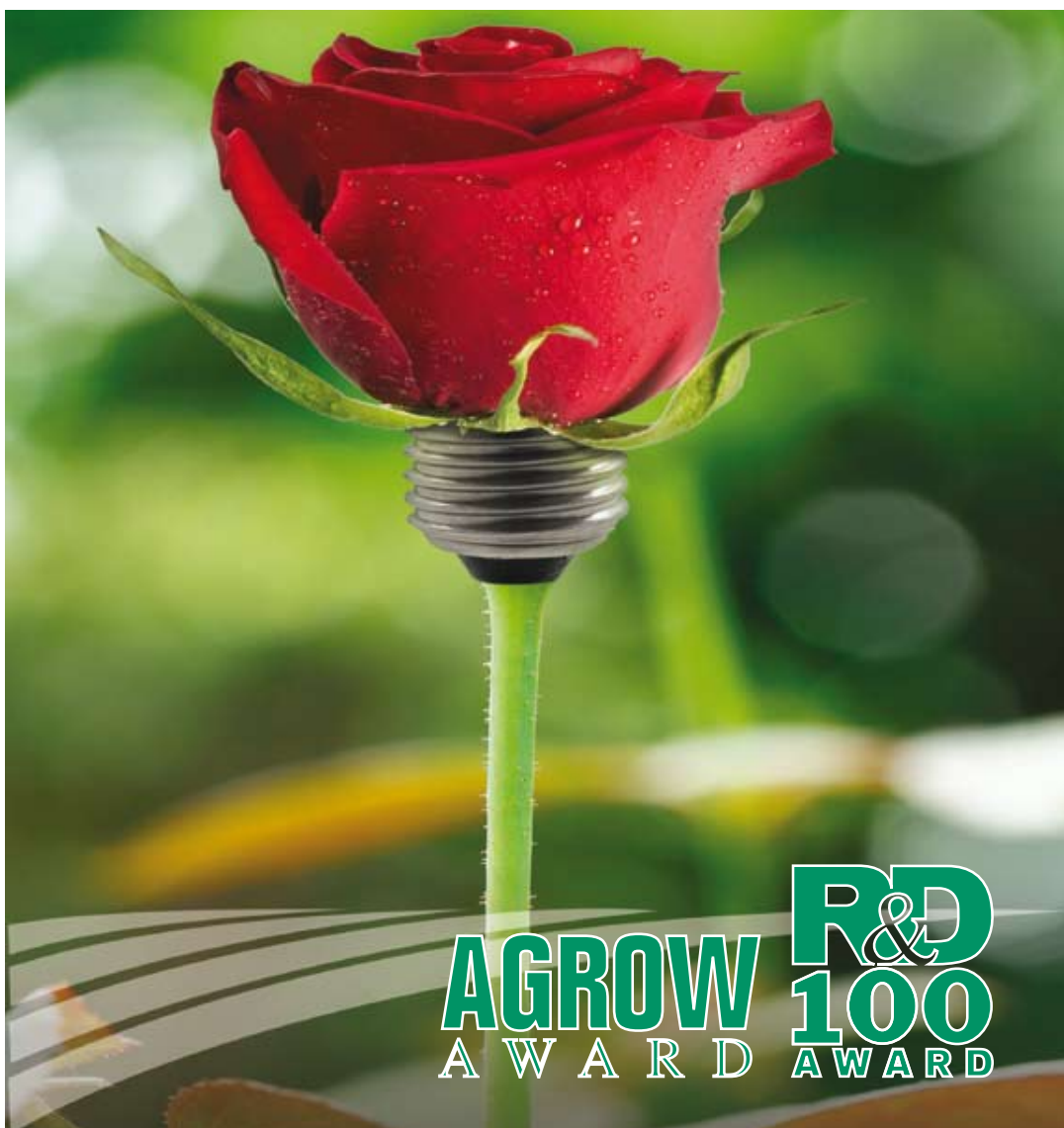

AGROW
A W A R D

R&D
100
A W A R D

UNIQUE TECHNOLOGY FROM THE INDUSTRY EXPERTS

Effective Residual Control

• mealy bugs • aphids • whiteflies

Closer™ 240SC

INSECTICIDE

ISOCLAST
ACTIVE

For more information please contact the registration holder: Dow Chemical East Africa Ltd. • 14 Riverside, Off Riverside Drive, Cavendish Block, Suite 1B • P.O. Box 2170-00606, Nairobi, Kenya • Tel +254 20 421 3000 • Fax +254 20 421 3030 • www.dowagro.com

Lachlan Kenya Limited: Tel + 254 20 2073912 • Fax + 254 20 2060260 • Mobile + 254 722 522749 • P.O. Box 49470, Nairobi, 00100, Kenya

ALWAYS USE ACCORDING TO LABEL RECOMMENDATIONS • Closer™ 240SC contains isoclast (Caution) | Reg. No. PCPB(CR)1359 • Closer™ are registered trademarks of Dow AgroSciences LLC



Dow AgroSciences

Solutions for the Growing World

© TM Trademark of The Dow Chemical Company ("Dow") or an affiliated company of Dow



KEKKILÄ PROFESSIONAL GROWING MEDIA



Kekkilä Professional growing media solutions for plants are made of carefully selected raw materials, ensuring outstanding quality in every bale.

It's benefits include:

- Properly aerated to ensure proper root development
- The media is free from fungal spores and bacteria
- Increases the germination percentage rate

Plants for propagation include: all flowers, all vegetables, all herbs, pot plants, forest and nursery stock.

Old Airport North Rd - Embakasi
P.O. Box 30327-00100, Nairobi
Tel: 0719 095 262
Email: fert@amirankenya.com

